



UTRON

Rev. 1.5

勝特力材料 886-3-5753170
 勝特力电子(上海) 86-21-54151736
 勝特力电子(深圳) 86-755-83298787
 Http://www.100y.com.tw

UT62256

32K X 8 BIT LOW POWER CMOS SRAM

FEATURES

- Access time : 35/70ns (max.)
- Low power consumption:
 Operating : 60/40 mA (typical.)
 Standby : 3mA (typical) normal
 2uA (typical) L-version
 1uA (typical) LL-version
- Single 5V power supply
- All inputs and outputs are TTL compatible
- Fully static operation
- Three state outputs
- Data retention voltage : 2V (min.)
- Package : 28-pin 600 mil PDIP
 28-pin 330 mil SOP
 28-pin 8x13.4mm STSOP

GENERAL DESCRIPTION

The UT62256 is a 262,144-bit low power CMOS static random access memory organized as 32,768 words by 8 bits. It is fabricated using high performance, high reliability CMOS technology.

The UT62256 is designed for high-speed and low power application. It is particularly well suited for battery back-up nonvolatile memory application.

The UT62256 operates from a single 5V power supply and all inputs and outputs are fully TTL compatible

FUNCTIONAL BLOCK DIAGRAM

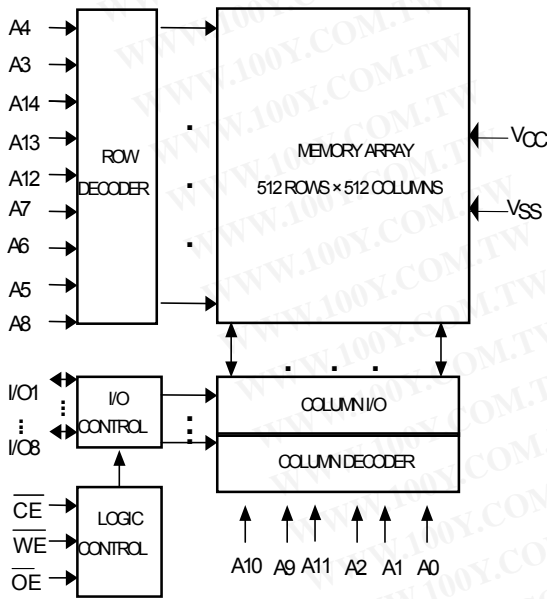

PIN CONFIGURATION

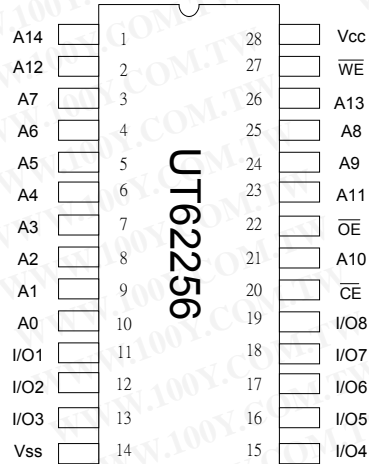

PIN DESCRIPTION

SYMBOL	DESCRIPTION
A0 - A14	Address Inputs
I/O1 - I/O8	Data Inputs/Outputs
CE	Chip Enable Input
WE	Write Enable Input
OE	Output Enable Input
V _{CC}	Power Supply
V _{SS}	Ground

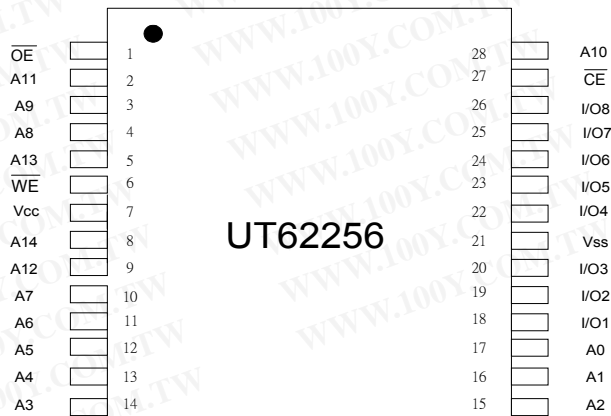

STSOP



Rev. 1.5

UTRON

勝特力材料 886-3-5753170
 勝特力电子(上海) 86-21-54151736
 勝特力电子(深圳) 86-755-83298787
[Http://www.100y.com.tw](http://www.100y.com.tw)

UT62256

32K X 8 BIT LOW POWER CMOS SRAM

ABSOLUTE MAXIMUM RATINGS*

PARAMETER	SYMBOL	RATING	UNIT
Terminal Voltage with Respect to V _{SS}	V _{TERM}	-0.5 to +7.0	V
Operating Temperature	T _A	0 to +70	°C
Storage Temperature	T _{STG}	-65 to +150	°C
Power Dissipation	P _D	1	W
DC Output Current	I _{OUT}	50	mA
Soldering Temperature (under 10 sec0	T _{solder}	260	°C

*Stresses greater than those listed under "Absolute Maximum Ratings" may cause permanent damage to the device. This is a stress rating only and functional operation of the device or any other conditions above those indicated in the operational sections of this specification is not implied. Exposure to the absolute maximum rating conditions for extended period may affect device reliability.

TRUTH TABLE

MODE	\overline{CE}	\overline{OE}	\overline{WE}	I/O OPERATION	SUPPLY CURRENT
Standby	H	X	X	High - Z	ISB, ISB1
Output Disable	L	H	H	High - Z	I _{CC}
Read	L	L	H	D _{OUT}	I _{CC}
Write	L	X	L	D _{IN}	I _{CC}

Note: H = V_{IH}, L = V_{IL}, X = Don't care.

DC ELECTRICAL CHARACTERISTICS (V_{CC} = 5V±10%, T_A = 0°C to 70°C)

PARAMETER	SYMBOL	TEST CONDITION	MIN.	TYP.	MAX.	UNIT	
Input High Voltage	V _{IH}		2.2	-	V _{CC} +0.5	V	
Input Low Voltage	V _{IL}		-0.5	-	0.8	V	
Input Leakage Current	I _{LI}	V _{SS} ≤ V _{IN} ≤ V _{CC}	-1	-	1	μA	
Output Leakage Current	I _{LO}	V _{SS} ≤ V _{I/O} ≤ V _{CC} $\overline{CE} = V_{IH}$ or $\overline{OE} = V_{IH}$ or $\overline{WE} = V_{IL}$	-1	-	1	μA	
Output High Voltage	V _{OH}	I _{OH} = -1mA	2.4	-	-	V	
Output Low Voltage	V _{OL}	I _{OL} = 4mA	-	-	0.4	V	
Operating Power Supply Current	I _{CC}	Cycle time=Min, I _{I/O} = 0mA, $\overline{CE} = V_{IL}$,	-35	-	60	100	mA
			-70	-	40	70	mA
Standby Power Supply Current	I _{SB}	$\overline{CE} = V_{IH}$	normal	-	1	10	mA
	I _{SB1}	$\overline{CE} \cong V_{CC}-0.2V$		-	0.3	5	mA
	I _{SB}	$\overline{CE} = V_{IH}$	-L/-LL	-	-	3	mA
	I _{SB1}	$\overline{CE} \cong V_{CC}-0.2V$	-L	-	2	100	μA
			-LL	-	1	50	μA



Rev. 1.5

UTRON

勝特力材料 886-3-5753170
 勝特力电子(上海) 86-21-54151736
 勝特力电子(深圳) 86-755-83298787
[Http://www.100y.com.tw](http://www.100y.com.tw)

UT62256

32K X 8 BIT LOW POWER CMOS SRAM

CAPACITANCE (TA=25°C, f=1.0MHz)

PARAMETER	SYMBOL	MIN.	MAX	UNIT
Input Capacitance	C _{IN}	-	8	pF
Input/Output Capacitance	C _{I/O}	-	10	pF

Note : These parameters are guaranteed by device characterization, but not production tested.

AC TEST CONDITIONS

Input Pulse Levels	0V to 3.0V
Input Rise and Fall Times	5ns
Input and Output Timing Reference Levels	1.5V
Output Load	C _L = 100pF, I _{OH} /I _{OL} = -1mA/4mA

AC ELECTRICAL CHARACTERISTICS (V_{CC} = 5V±10%, TA = 0°C to 70°C)**(1) READ CYCLE**

PARAMETER	SYMBOL	UT62256-35		UT62256-70		UNIT
		MIN.	MAX.	MIN.	MAX.	
Read Cycle Time	t _{RC}	35	-	70	-	ns
Address Access Time	t _{AA}	-	35	-	70	ns
Chip Enable Access Time	t _{ACE}	-	35	-	70	ns
Output Enable Access Time	t _{OE}	-	25	-	35	ns
Chip Enable to Output in Low Z	t _{CLZ} *	10	-	10	-	ns
Output Enable to Output in Low Z	t _{OLZ} *	5	-	5	-	ns
Chip Disable to Output in High Z	t _{CHZ} *	-	25	-	35	ns
Output Disable to Output in High Z	t _{OHZ} *	-	25	-	35	ns
Output Hold from Address Change	t _{OH}	5	-	5	-	ns

(2) WRITE CYCLE

PARAMETER	SYMBOL	UT62256-35		UT62256-70		UNIT
		MIN.	MAX.	MIN.	MAX.	
Write Cycle Time	t _{WC}	35	-	70	-	ns
Address Valid to End of Write	t _{AW}	30	-	60	-	ns
Chip Enable to End of Write	t _{CW}	30	-	60	-	ns
Address Set-up Time	t _{AS}	0	-	0	-	ns
Write Pulse Width	t _{WP}	25	-	50	-	ns
Write Recovery Time	t _{WR}	0	-	0	-	ns
Data to Write Time Overlap	t _{DW}	20	-	30	-	ns
Data Hold from End of Write Time	t _{DH}	0	-	0	-	ns
Output Active from End of Write	t _{OW} *	5	-	5	-	ns
Write to Output in High Z	t _{WHZ} *	-	15	-	25	ns

*These parameters are guaranteed by device characterization, but not production tested.



Rev. 1.5

UTRON

勝特力材料 886-3-5753170
 勝特力电子(上海) 86-21-54151736
 勝特力电子(深圳) 86-755-83298787
[Http://www.100y.com.tw](http://www.100y.com.tw)

UT62256

32K X 8 BIT LOW POWER CMOS SRAM

TIMING WAVEFORMS

READ CYCLE 1 (Address Controlled) (1,2,4)

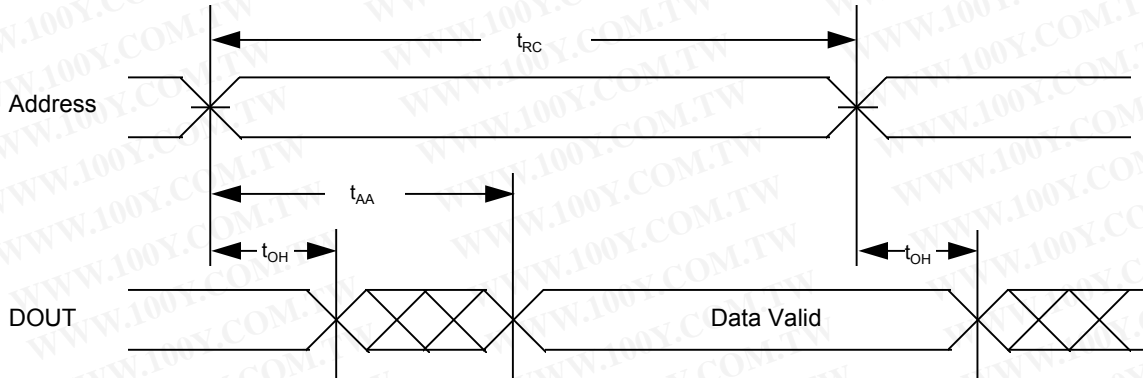

READ CYCLE 2 (\overline{CE} and \overline{OE} Controlled) (1,3,5,6)

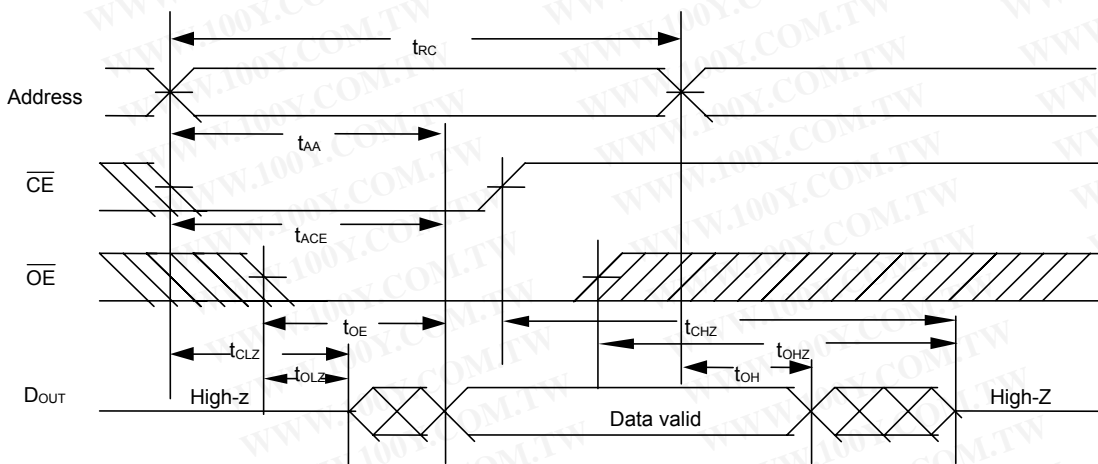

Notes :

- \overline{WE} is HIGH for read cycle.
- Device is continuously selected $\overline{CE} = V_{IL}$.
- Address must be valid prior to or coincident with \overline{CE} transition; otherwise t_{AA} is the limiting parameter.
- \overline{OE} is LOW.
- t_{CLZ} , t_{OLZ} , t_{CHZ} and t_{OHZ} are specified with $C_L = 5pF$. Transition is measured $\pm 500mV$ from steady state.
- At any given temperature and voltage condition, t_{CHZ} is less than t_{CLZ} , t_{OHZ} is less than t_{OLZ} .



Rev. 1.5

UTRON

勝特力材料 886-3-5753170
 勝特力电子(上海) 86-21-54151736
 勝特力电子(深圳) 86-755-83298787
[Http://www.100y.com.tw](http://www.100y.com.tw)

UT62256

32K X 8 BIT LOW POWER CMOS SRAM

WRITE CYCLE 1 (\overline{WE} Controlled) (1,2,3,5)

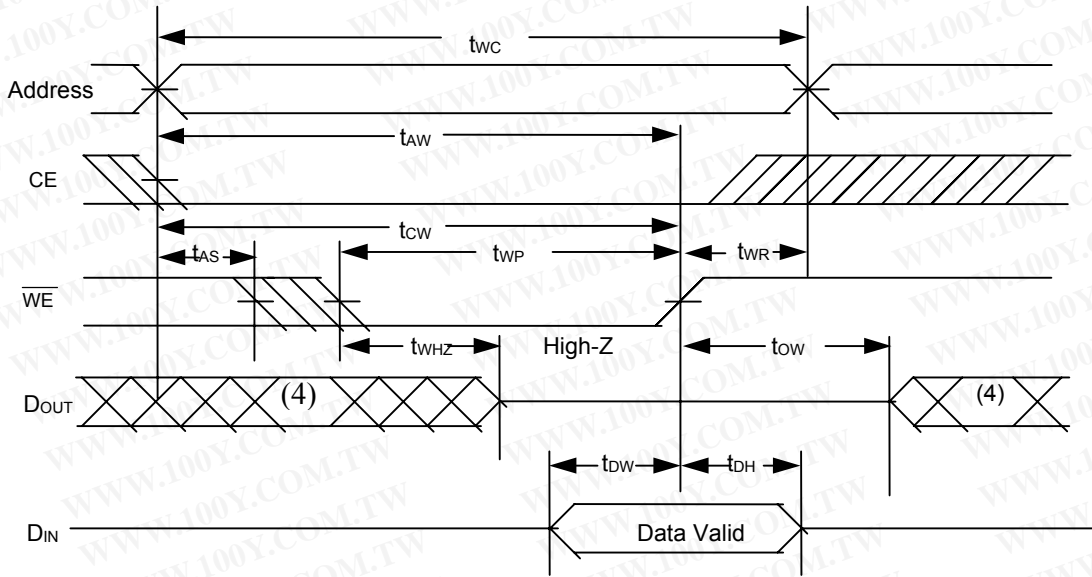

WRITE CYCLE 2 (\overline{CE} Controlled) (1,2,5)

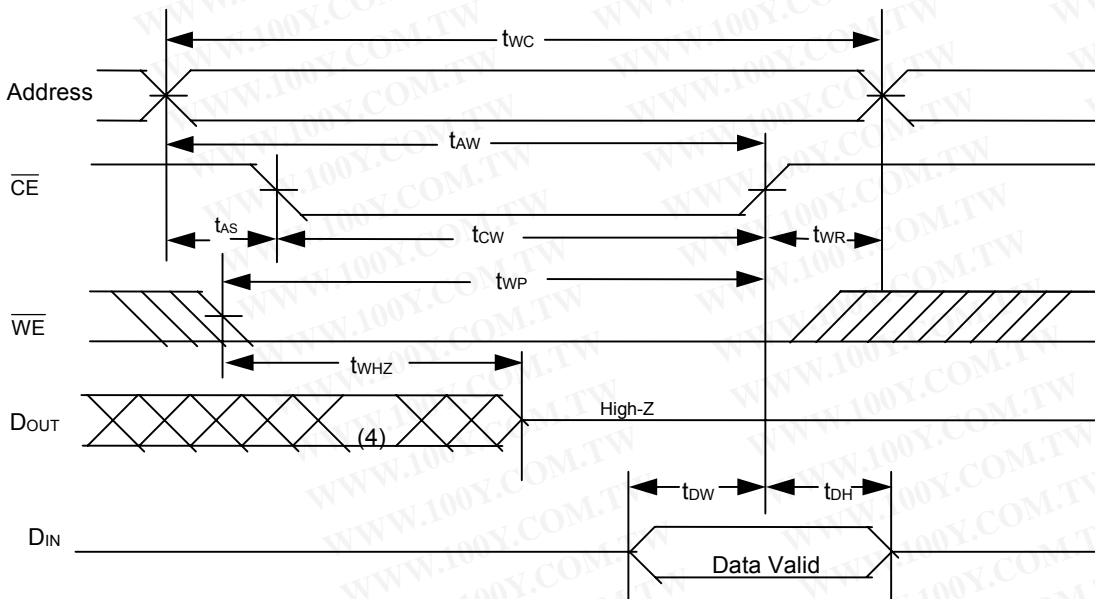

Notes :

1. \overline{WE} or \overline{CE} must be HIGH during all address transitions.
2. A write occurs during the overlap of a low \overline{CE} and a low \overline{WE} .
3. During a \overline{WE} controlled write cycle with \overline{OE} LOW, t_{WP} must be greater than $t_{WHZ} + t_{OW}$ to allow the drivers to turn off and data to be placed on the bus.
4. During this period, I/O pins are in the output state, and input signals must not be applied.
5. If the \overline{CE} LOW transition occurs simultaneously with or after \overline{WE} LOW transition, the outputs remain in a high impedance state.
6. t_{OW} and t_{WHZ} are specified with $C_L = 5pF$. Transition is measured $\pm 500mV$ from steady state.



Rev. 1.5

UTRON

勝特力材料 886-3-5753170
 勝特力电子(上海) 86-21-54151736
 勝特力电子(深圳) 86-755-83298787
[Http://www.100y.com.tw](http://www.100y.com.tw)

UT62256

32K X 8 BIT LOW POWER CMOS SRAM

DATA RETENTION CHARACTERISTICS (TA = 0°C to 70°C)

PARAMETER	SYMBOL	TEST CONDITION	MIN.	TYP.	MAX.	UNIT		
Vcc for Data Retention	V _{DR}	$\overline{CE} \geq V_{cc}-0.2V$	2.0	-	5.5	V		
Data Retention Current	I _{DR}	V _{cc} =3V	- L	-	1	50 20*	μA μA	
			- LL	-	0.5	20 5*	μA μA	
		$\overline{CE} \geq V_{cc}-0.2V$	- L	-	-	-	-	-
			- LL	-	-	-	-	-
Chip Disable to Data Retention Time	t _{CDR}	See Data Retention Waveforms (below)	0	-	-	ns		
Recovery Time	t _R		t _{RC} *	-	-	ns		

t_{RC}* = Read Cycle Time

* Those parameters are limited for temperature below 40°C

DATA RETENTION WAVEFORM

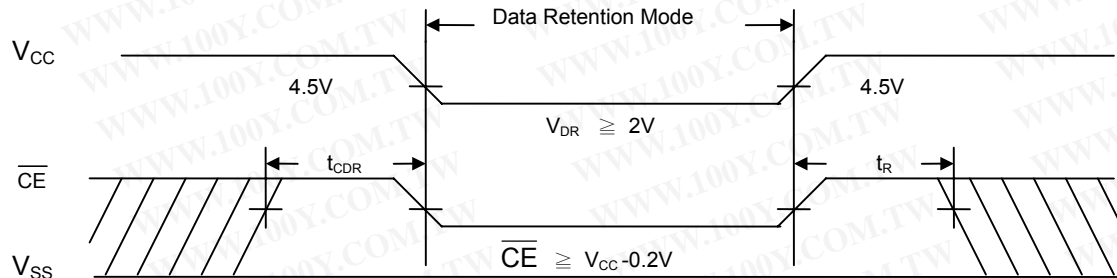



Rev. 1.5

UTRON

勝特力材料 886-3-5753170
 勝特力电子(上海) 86-21-54151736
 勝特力电子(深圳) 86-755-83298787
 Http://www.100y.com.tw

UT62256

32K X 8 BIT LOW POWER CMOS SRAM

PACKAGE OUTLINE DIMENSION

28 pin 600 mil PDIP Package Outline Dimension

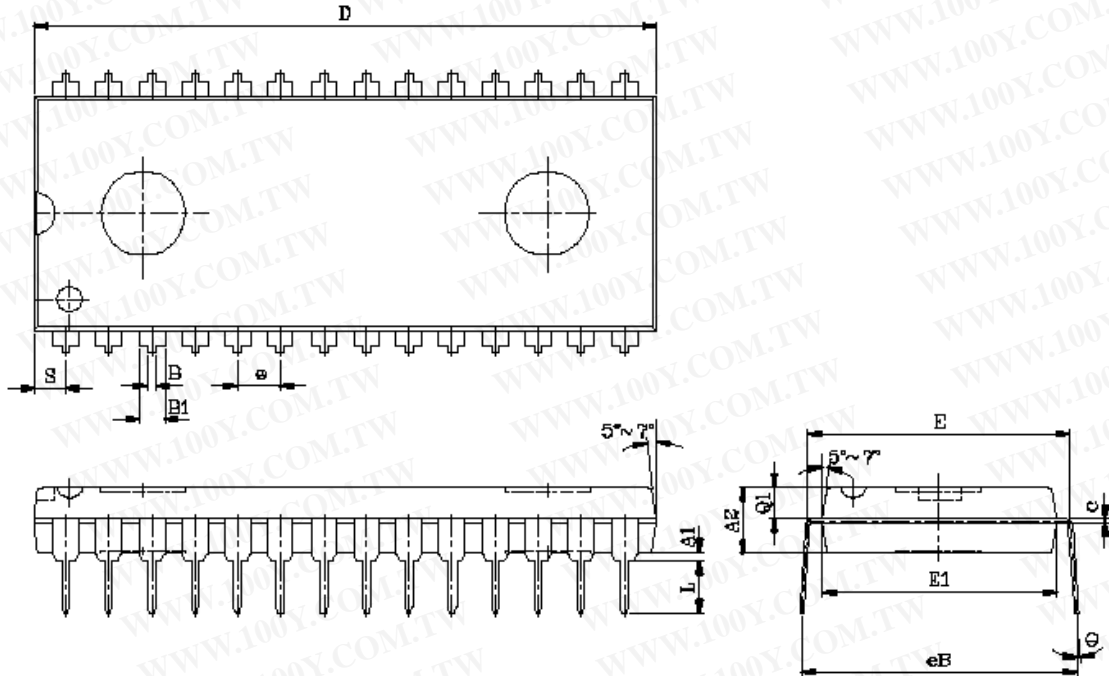

SYMBOL	UNIT	INCH(BASE)	MM(REF)
A1		0.010 (MIN)	0.254 (MIN)
A2		0.150±0.005	3.810±0.127
B		0.020 (MAX)	0.508(MAX)
B1		0.055 (MAX)	1.397(MAX)
c		0.012 (MAX)	0.304 (MAX)
D		1.430 (MAX)	36.322 (MAX)
E		0.6 (TYP)	15.24 (TYP)
E1		0.52 (MAX)	13.208 (MAX)
e		0.100 (TYP)	2.540(TYP)
eB		0.625 (MAX)	15.87 (MAX)
L		0.180(MAX)	4.572(MAX)
S		0.06 (MAX)	1.524 (MAX)
Q1		0.08(MAX)	2.032(MAX)
θ		15°(MAX)	15°(MAX)





Rev. 1.5

UTRON

勝特力材料 886-3-5753170
 勝特力电子(上海) 86-21-54151736
 勝特力电子(深圳) 86-755-83298787
 Http://www.100y.com.tw

UT62256

32K X 8 BIT LOW POWER CMOS SRAM

28 pin 330 mil SOP Package Outline Dimension

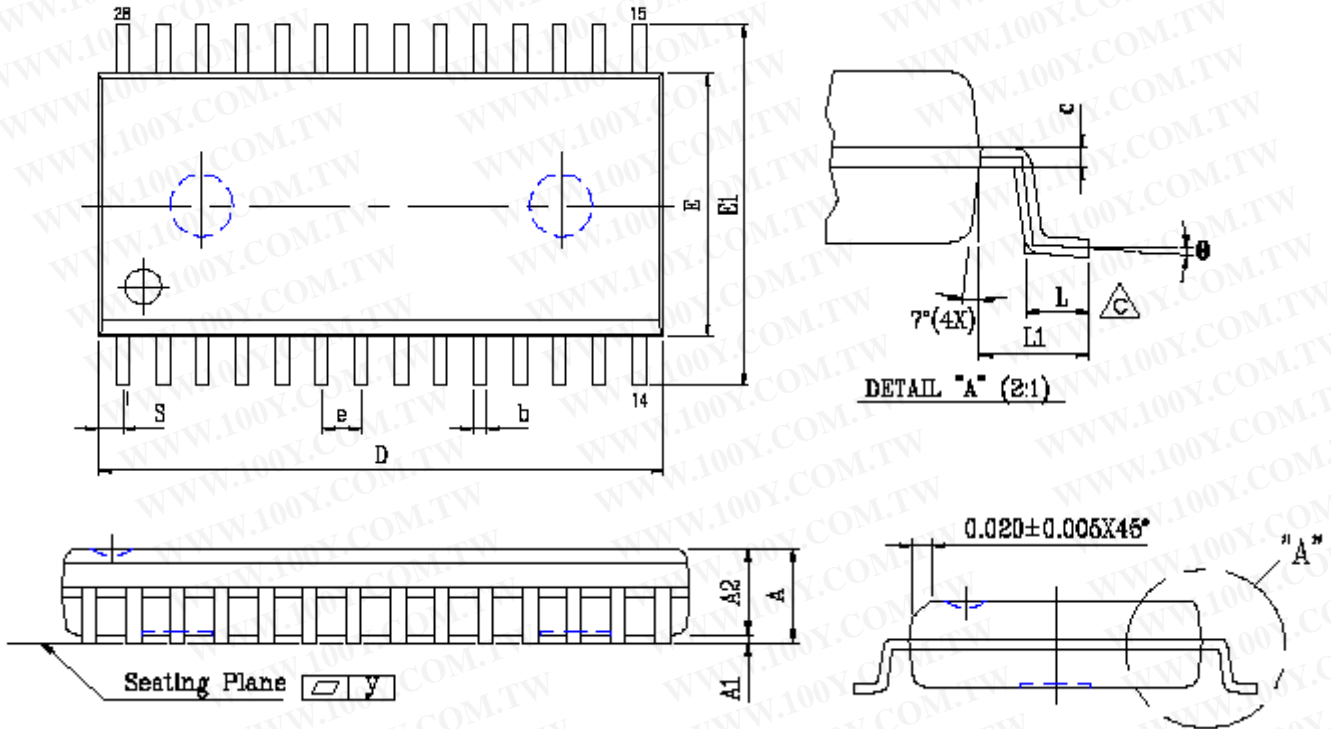

SYMBOL	UNIT	INCH(BASE)	MM(REF)
A		0.120 (MAX)	3.048 (MAX)
A1		0.002(MIN)	0.05(MIN)
A2		0.098±0.005	2.489±0.127
b		0.0016 (TYP)	0.406(TYP)
c		0.010 (TYP)	0.254(TYP)
D		0.728 (MAX)	18.491 (MAX)
E		0.340 (MAX)	8.636 (MAX)
E1		0.465±0.012	11.811±0.305
e		0.050 (TYP)	1.270(TYP)
L		0.05 (MAX)	1.270 (MAX)
L1		0.067±0.008	1.702 ±0.203
S		0.047 (MAX)	1.194 (MAX)
y		0.003(MAX)	0.076(MAX)
θ		0°~10°	0°~10°





Rev. 1.5

UTRON

勝特力材料 886-3-5753170
 勝特力电子(上海) 86-21-54151736
 勝特力电子(深圳) 86-755-83298787
 Http://www.100y.com.tw

UT62256

32K X 8 BIT LOW POWER CMOS SRAM

28 pin 8mmx13.4mm STSOP Package Outline Dimension

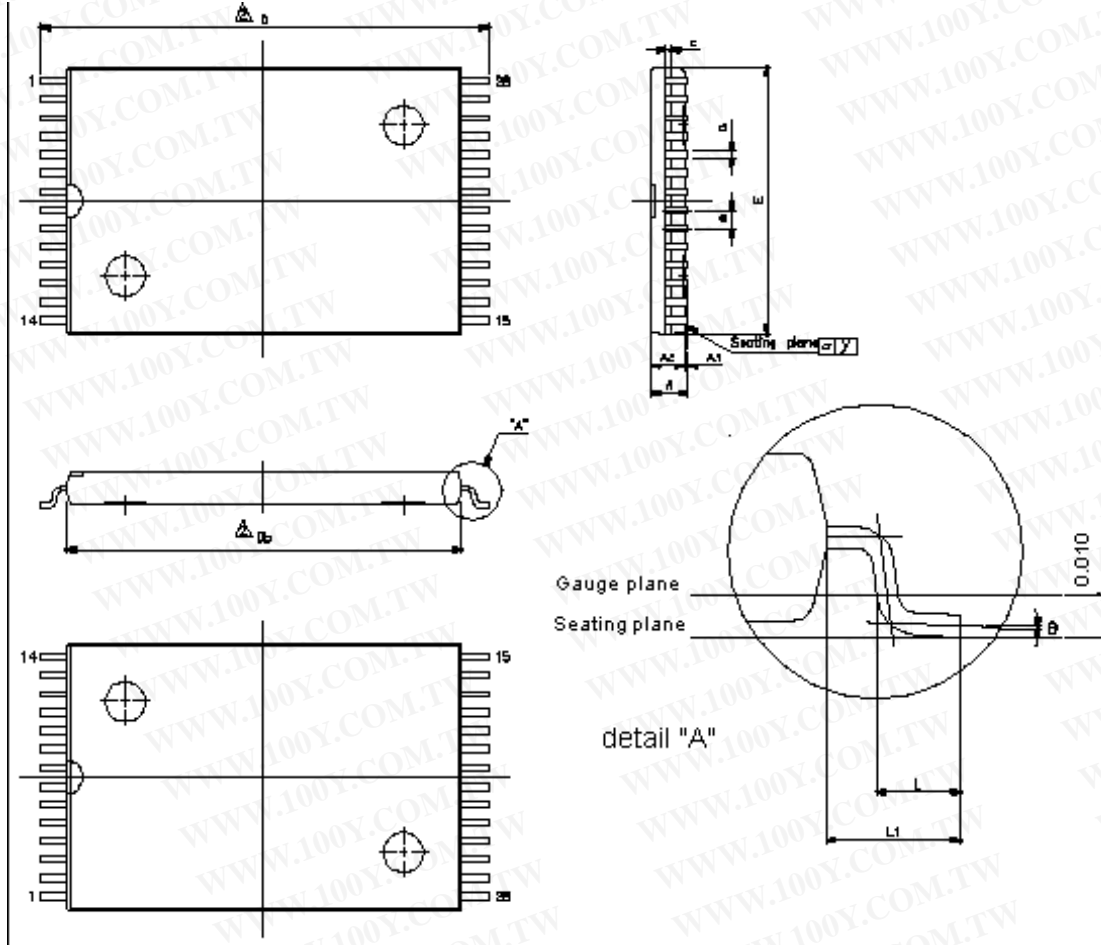

Note :
 E dimension is not including end flash
 the total of both sides' end flash is
 not above 0.3mm.



UNIT SYMBOL	INCH(BASE)	MM(REF)
A	0.047 (MAX)	1.20 (MAX)
A1	0.004±0.002	0.10±0.05
A2	0.039±0.002	1.00±0.05
b	0.006 (TYP)	0.15(TYP)
c	0.010 (TYP)	0.254(TYP)
Db	0.465±0.004	11.80±0.10
E	0.315±0.004	8.00±0.10
e	0.022 (TYP)	0.55(TYP)
D	0.528±0.008	13.40±0.20
L	0.020±0.004	0.50±0.10
L1	0.0315±0.004	0.80±0.10
y	0.08(MAX)	0.003(MAX)
θ	0°~5°	0°~5°



Rev. 1.5

UTRON

勝特力材料 886-3-5753170

勝特力电子(上海) 86-21-54151736

勝特力电子(深圳) 86-755-83298787

[Http://www.100y.com.tw](http://www.100y.com.tw)

UT62256

32K X 8 BIT LOW POWER CMOS SRAM

ORDERING INFORMATION

PART NO.	ACCESS TIME (ns)	STANDBY CURRENT (μ A)	PACKAGE
UT62256PC-70	70	5 mA	28PIN PDIP
UT62256PC-70L	70	100 μ A	28PIN PDIP
UT62256PC-70LL	70	50 μ A	28PIN PDIP
UT62256SC-35	35	5 mA	28PIN SOP
UT62256SC-35L	35	100 μ A	28PIN SOP
UT62256SC-35LL	35	50 μ A	28PIN SOP
UT62256SC-70	70	5 mA	28PIN SOP
UT62256SC-70L	70	100 μ A	28PIN SOP
UT62256SC-70LL	70	50 μ A	28PIN SOP
UT62256LS-35L	35	100 μ A	28PIN STSOP
UT62256LS-35LL	35	50 μ A	28PIN STSOP
UT62256LS-70L	70	100 μ A	28PIN STSOP
UT62256LS-70LL	70	50 μ A	28PIN STSOP



Rev. 1.5

UTRON

勝特力材料 886-3-5753170
勝特力电子(上海) 86-21-54151736
勝特力电子(深圳) 86-755-83298787
[Http://www.100y.com.tw](http://www.100y.com.tw)

UT62256

32K X 8 BIT LOW POWER CMOS SRAM

REVISION HISTORY

REVISION	DESCRIPTION	DATE
REV. 1.0	Original.	
REV 1.1	The value of symbol "E" is revised as 0.35 inch.	AUG. 24,1999
REV. 1.2	Combine version_UT62256(normal) and version_UT62256SC-35 into version_UT62256	DEC. 8,1999
REV. 1.4	1. The pin configurations' name of TSOP-1 is revised as STSOP. 2. The data retention waveform, $\overline{CE} \geq V_{CC}-0.2V$. (page 6)	MAY. 10,2001
REV. 1.5	Add data retention current for temperature below 40°C.	JUL.11 ,2001