

Low-voltage Electronic Speech circuit with Dialer Interface

Description

The electronic speech circuit, U4056B1, is a linear integrated circuit for use in telephones and other line fed terminal equipment. It replaces the common speech circuit with carbon microphone, hybrid transformer,

sidetone equivalent and ear protection rectifiers. A low-cost electrodynamic transducer is used as an earphone. It contains all components necessary for amplification of signals and adaption to the line.

Features

- The microphone hybrid transformer is replaced by an electronic circuit
- Asymmetrical input for electret microphone
- High performance through the use of dynamic transducers as the earphone (non-linear distortion $\leq 2\%$)
- Optional automatic equalization of sending and receiving reference equivalent up to 5 km subscriber line length
- DTMF interface with muting
- Supply voltage for dialer
- High range of line feeding current
- Input resistance independent of line current and sidetone suppression circuit
- Built-in ear protection by earphone voltage limiter
- High life expectancy due to reduced power consumption on the chip

Benefits

- Operation possible from 5 mA

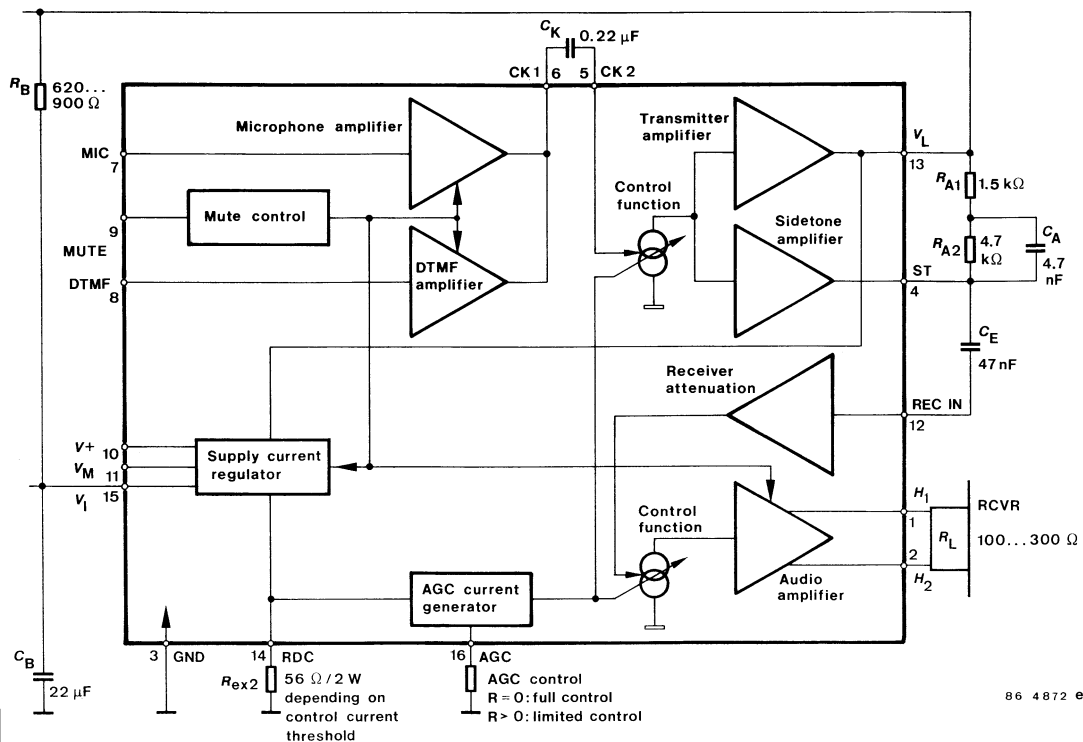

U4056B1: High level mute

Figure 1. Block diagram and pin connection

Pin Description

Pin	Symbol	Function
1, 2	H1 and H2	The push-pull complementary outputs of the receive amplifier: Dynamic transducers with a minimum impedance of 100 Ω can be directly driven by these outputs.
3	GND	Ground
4	Sidetone ST	The output of the sidetone cancellation signal, requires a balanced impedance of eight to ten times the subscriber's line impedance to be connected to Pin 13.
5	CK2	Input to the line output driver amplifier. Transmit a.g.c. is applied to this stage.
6	CK1	The transmit pre-amp output respective of the DTMF output which is normally capacitively coupled to Pin 5.
7	MIC IN	This input is intended to be capacitively coupled to a FET-buffered electret microphone
8	DTMF IN	The DTMF input has an internal resistor connected to ground. It provides the load resistor for the emitter of a CMOS DTMF generator. This input is only active when MUTE (Pin 9) is pulled high.
9	MUTE	The MUTE input must be pulled at least to 1.5 V (MUTE) to mute the MIC amp. and audio amp. and enable DTMF IN.
10	V+	Regulated output voltage of 2.7 V for biasing a DTMF generator activated by MUTE

Pin	Symbol	Function
11	V _M	Regulated output voltage of 1.2 V suitable for low-voltage electret microphone
12	REC IN	The receive amplifier input. The receiving amplification is regulated by an a.g.c.
13	V _L	Positive supply voltage input to the device. This input should be connected to the positive output of the polarity guard. The current through this pin is modulated by the transmit signal.
14	R _{DC}	An external resistor (2 W) is required from this pin to GND to control the dc input impedance of the circuit. It has a nominal value of 56 Ω for low-voltage operation. Values up to 100 Ω may be used to increase the available transmit output voltage swing at the expense of low-voltage operation.
15	V _I	This internal voltage bias line must be connected to V _L via an external resistor R _B , which dominates the ac input impedance of the circuit and should be 620 Ω for an 600 Ω input impedance or 910 Ω for a 900 Ω input impedance.
16	R _{AGC}	The range of transmit and receive gain variations between short and long loops may be adjusted by connecting a resistor, R _{EX1} , from this pin to Pin 3 (GND). This pin can be left open to set a.g.c. out of action.

Pin Description

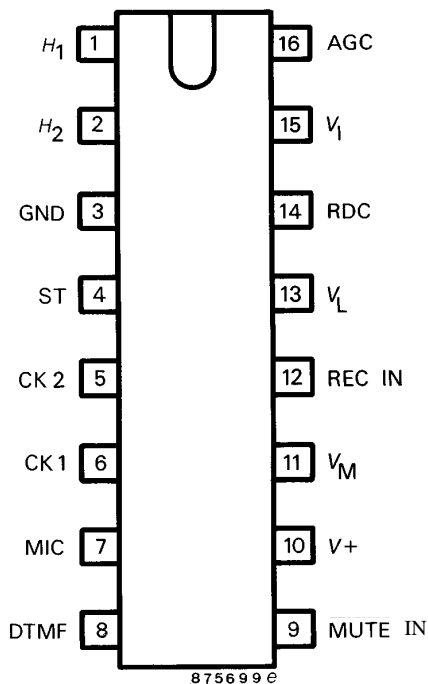

Figure 2.

Absolute Maximum Ratings

Reference point Pin 3, unless otherwise specified

Parameters	Symbol	Value	Unit
Line current	I_L	200	mA
DC line voltage, $t_p = 3$ ms, Pin 13	V_L	20	V
Power dissipation, $I_L = 100$ mA	P_{tot}	560	mW
Junction temperature	T_j	150	°C
Ambient temperature range	T_{amb}	-28 to +80	°C
Storage temperature range	T_{stg}	-55 to +150	°C

Thermal Resistance

Parameters	Symbol	Value	Unit
Junction ambient	R_{thJA}	85	K/W

Electrical Characteristics

Reference point Pin 3, cable equivalent $l = 1 \text{ km}$, $\varnothing 0.5 \text{ mm}$, $R' = 184 \Omega$, $C' = 37 \text{ nF}$, $f = 1300 \text{ Hz}$, $0 \text{ dB}_m = 775 \text{ mV}_{\text{rms}}$, $R_{EX2} = 56 \Omega / 2 \text{ W}$, $T_{\text{exch}} = 48 \text{ V}$, $R_{EX2} = 500 \Omega$, $T_{\text{amb}} = 25^\circ\text{C}$, unless otherwise specified.

Parameters	Test Conditions / Pins	Symbol	Min.	Typ.	Max.	Unit
Line voltage	$I_L = 5 \text{ mA}$	V_L	1.3	1.7	2.1	V
	$I_L = 20 \text{ mA}$		2.7	3.0	3.3	
	$I_L = 30 \text{ mA}$		3.6	4.0	4.5	
	$I_L = 73 \text{ mA}$		7.5	8.5	9.5	
see figure 3						
Transmit and sidestone see figure 4 and 6						
Input resistance	Pin 7 - 3		23	28	33	k Ω
Gain	$I_L = 30 \text{ mA}$	G_s	32	34	36	dB
	$30 \leq I_L \leq 73 \text{ mA}$	ΔG_s	-6			
Noise at line weighted psophometrically	$I_L = 73 \text{ mA}$	n_o		-72		dBmp
Sidetone reduction	$0 \leq l \leq 5 \text{ km}$	G_{STR}	10	15	20	dB
DTMF Amplifier						
Input resistance	Pin 8 - 3	R_D	8	10	13	k Ω
DTMF Gain	$I_L = 30 \text{ mA}$	G_D	8	10	12	dB
	$31 \text{ mA} \leq I_L \leq 73 \text{ mA}$	ΔG_D		-6	-9	dB
Volume range $d \geq 5\%$	$I_L = 30 \text{ mA}$	V_0	0.9	1		V_{RMS}
Receiving amplifier see figure 5						
Input resistance	Pin 12 - 3	R_i	40	50	60	k Ω
Receiving amplifier gain	$R_{HH} = 300 \Omega$, $I_L = 30 \text{ mA}$	G_R	-1	-3	-5	dB
	$R_{HH} = 300 \Omega$ $30 \leq I_L \leq 73 \text{ mA}$	ΔG_R		-6		
Receiving noise at earphone weighted psophometrically	$I_L = 73 \text{ mA}$, $R_{HH} = 300 \Omega$	n_i		-80		dBmp
Gain change when muted	$I_L \geq 30 \text{ mA}$, $R_{HH} = 300 \Omega$	G_{RM}	15	20	26	dB
Output saturation threshold	$I_L \geq 20 \text{ mA}$, $R_{HH} = 300 \Omega$	V_0	1	1.5		V_{pp}
MUTE input						
MUTE-input current	Pin 9 = 1.5 V	I_M	10	20	30	μA
MUTE off input voltage		$V_{\text{M off}}$			0.3	V
MUTE on input voltage		$V_{\text{M on}}$	1.5			V
Supply voltage see figure 3						
Output voltage	$I_L \geq 20 \text{ mA}$ MUTE switched off switched on Pin 10	V_+	3		6.1	V
			2.5	2.9	3.1	
Output current	$I_L \geq 20 \text{ mA}$ MUTE switched off switched on $V_+ = 2.5 \text{ V}$ Pin 10	I_+		30		mA
			1.0	1.2		
Output voltage	$I_L \geq 20 \text{ mA}$ Pin 11	V_M	1.1	1.2	1.4	V
Output current	$I_L \geq 20 \text{ mA}$ Pin 11	I_M	300	400	600	μA

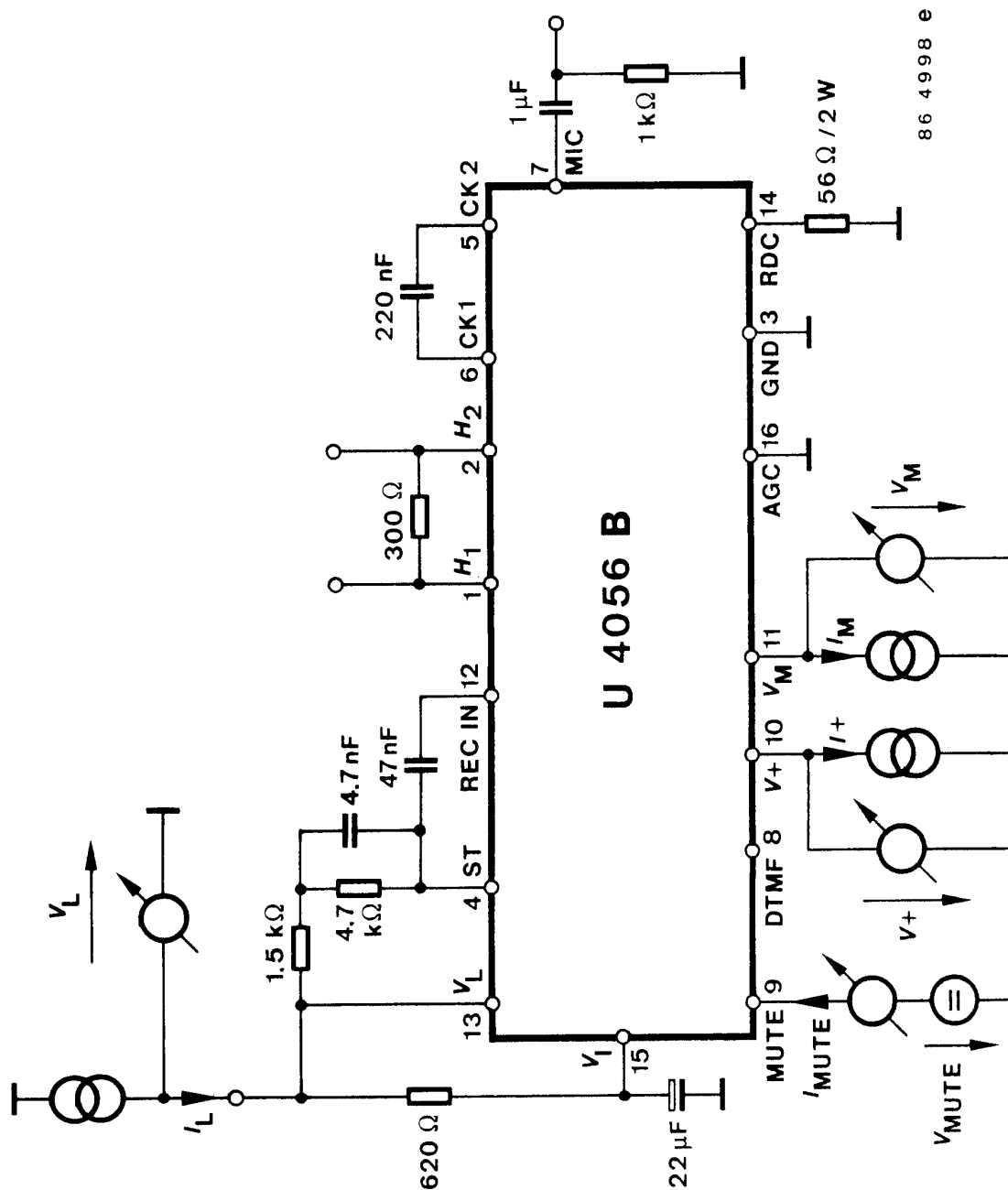

86 4998 e

Figure 3. Line and supply voltage characteristics

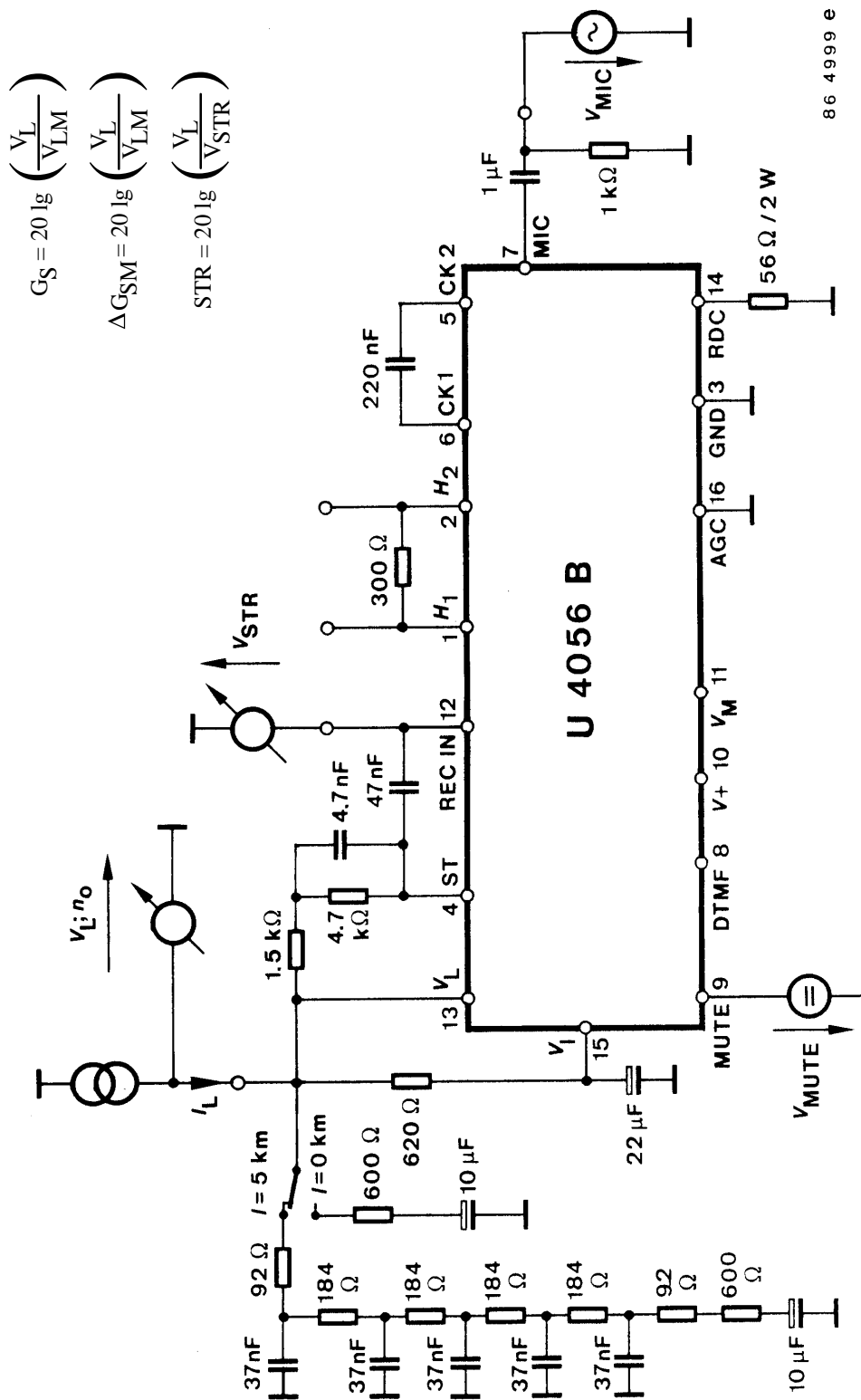

G_S : Sending gain at 0 km
 V_{LM} : Line voltage in mute condition

Figure 4. Transmitting amplification and sidetone reduction

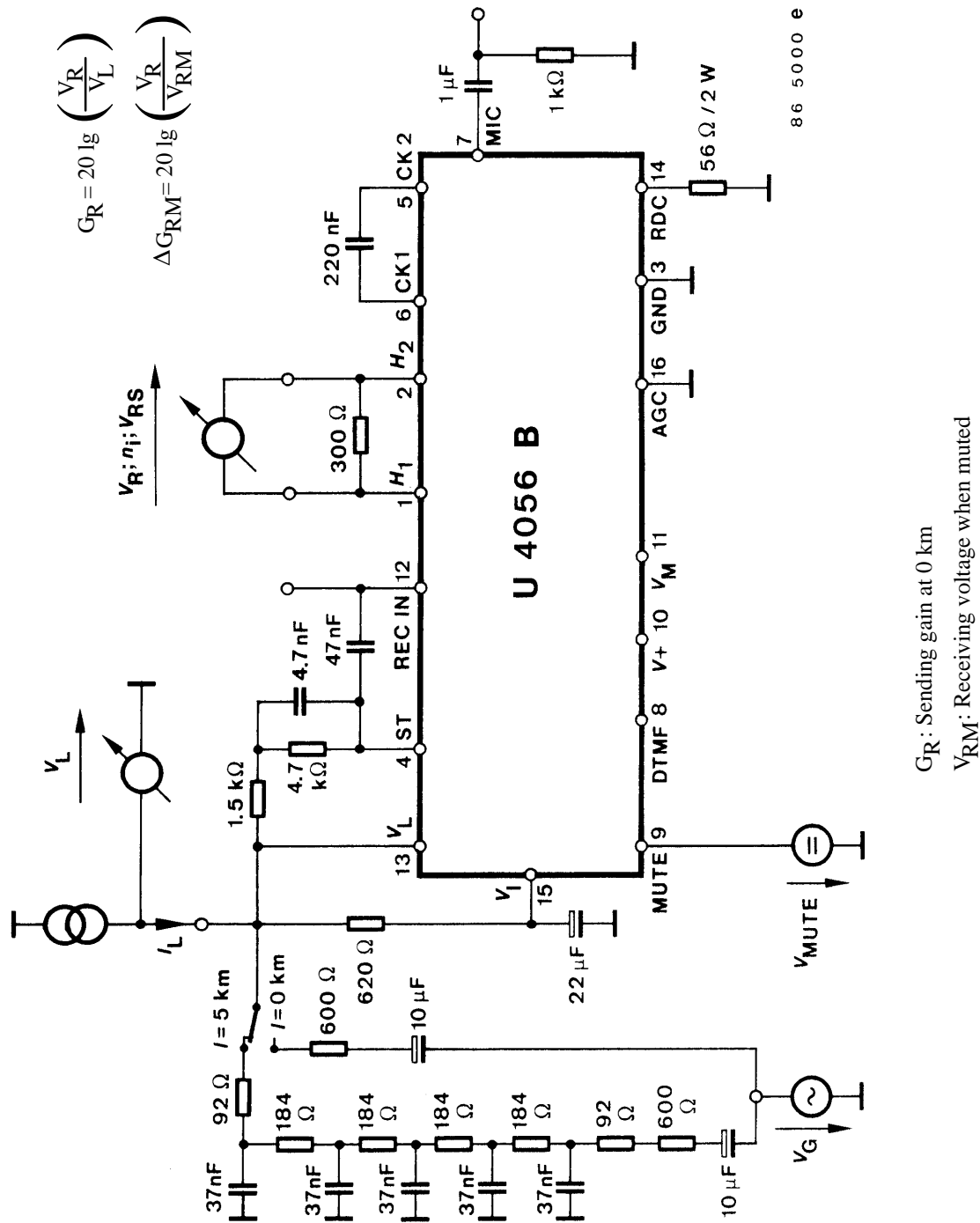

Figure 5. Receiving amplifier

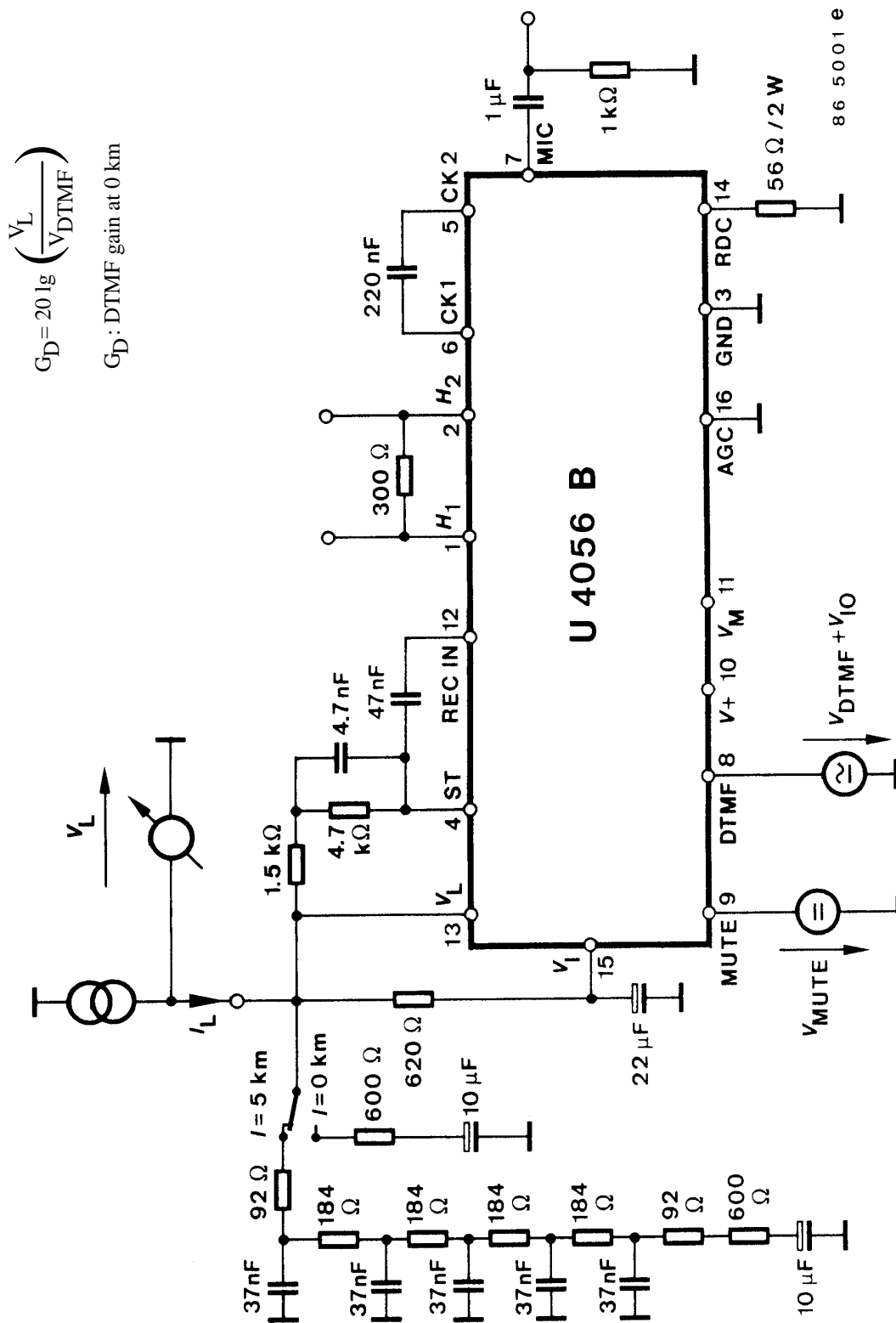

Figure 6. DTMF amplifier

Ordering Information

Extended Type Number	Package	Remarks
U4056B1	DIP16	

Dimensions in mm

Package: DIP16

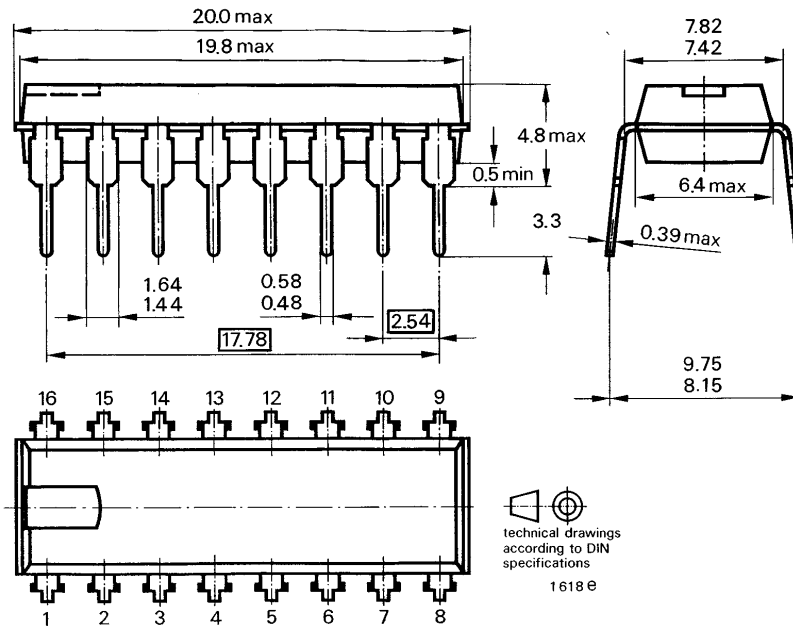

Ozone Depleting Substances Policy Statement

It is the policy of **TEMIC TELEFUNKEN microelectronic GmbH** to

1. Meet all present and future national and international statutory requirements.
2. Regularly and continuously improve the performance of our products, processes, distribution and operating systems with respect to their impact on the health and safety of our employees and the public, as well as their impact on the environment.

It is particular concern to control or eliminate releases of those substances into the atmosphere which are known as ozone depleting substances (ODSs).

The Montreal Protocol (1987) and its London Amendments (1990) intend to severely restrict the use of ODSs and forbid their use within the next ten years. Various national and international initiatives are pressing for an earlier ban on these substances.

TEMIC TELEFUNKEN microelectronic GmbH semiconductor division has been able to use its policy of continuous improvements to eliminate the use of ODSs listed in the following documents.

1. Annex A, B and list of transitional substances of the Montreal Protocol and the London Amendments respectively
2. Class I and II ozone depleting substances in the Clean Air Act Amendments of 1990 by the Environmental Protection Agency (EPA) in the USA
3. Council Decision 88/540/EEC and 91/690/EEC Annex A, B and C (transitional substances) respectively.

TEMIC can certify that our semiconductors are not manufactured with ozone depleting substances and do not contain such substances.

We reserve the right to make changes to improve technical design and may do so without further notice.

Parameters can vary in different applications. All operating parameters must be validated for each customer application by the customer. Should the buyer use TEMIC products for any unintended or unauthorized application, the buyer shall indemnify TEMIC against all claims, costs, damages, and expenses, arising out of, directly or indirectly, any claim of personal damage, injury or death associated with such unintended or unauthorized use.

TEMIC TELEFUNKEN microelectronic GmbH, P.O.B. 3535, D-74025 Heilbronn, Germany
Telephone: 49 (0)7131 67 2831, Fax number: 49 (0)7131 67 2423

This datasheet has been download from:

www.datasheetcatalog.com

Datasheets for electronics components.