

MR501, MR502, MR504 MR506, MR508, MR510

Designers Data Sheet

MINIATURE SIZE, AXIAL LEAD MOUNTED STANDARD RECOVERY POWER RECTIFIERS

... designed for use in power supplies and other applications having need of a device with the following features:

- High Current to Small Size
- High Surge Current Capability
- Low Forward Voltage Drop
- Void-Free Economical Plastic Package
- Available in Volume Quantities

Designer's Data for "Worst Case" Conditions

The Designers Data sheets permit the design of most circuits entirely from the information presented. Limit curves - representing boundaries on device characteristics - are given to facilitate "worst case" design.

MAXIMUM RATINGS

Rating	Symbol	MR 501	MR 502	MR 504	MR 506	MR 508	MR 510	Unit
Peak Repetitive Reverse Voltage	V_{RRM}	100	200	400	600	800	1000	Volts
Working Peak Reverse Voltage	V_{RWM}							
DC Blocking Voltage	V_R							
Non-Repetitive Peak Reverse Voltage	V_{RSM}	150	250	450	650	850	1050	Volts
Average Rectified Forward Current (Single phase resistive load, $T_A = 95^\circ\text{C}$, PC Board Mounting) (1) (EIA Standard Conditions $L = 1/32"$, $T_L = 85^\circ\text{C}$)	I_O	\longleftrightarrow 3.0 \longleftrightarrow \longleftrightarrow 8.0 \longleftrightarrow						Amp
Non-Repetitive Peak Surge Current (surge applied at rated load conditions)	I_{FSM}	\longleftrightarrow 100 \longleftrightarrow (one cycle)						Amp
Operating and Storage Junction Temperature Range (2)	T_J, T_{stg}	\longleftrightarrow -65 to +175 \longleftrightarrow						$^\circ\text{C}$

THERMAL CHARACTERISTICS

Characteristic	Symbol	Max	Unit
Thermal Resistance, Junction to Ambient (Recommended Printed Circuit Board Mounting, See Note 2 on Page 4).	$R_{\theta JA}$	28	$^\circ\text{C}/\text{W}$

ELECTRICAL CHARACTERISTICS

Characteristic	Symbol	Min	Typ	Max	Unit
Instantaneous Forward Voltage (3) ($I_F = 9.4$ Amp, $T_J = 175^\circ\text{C}$) ($I_F = 9.4$ Amp, $T_J = 25^\circ\text{C}$)	V_F	-	0.9 1.04	1.0 1.1	Volts
Reverse Current (rated dc voltage) (3) $T_J = 25^\circ\text{C}$ $T_J = 100^\circ\text{C}$	I_R	-	0.1 2.8	5.0 25	μA

- (1) Derate for reverse power dissipation. See Note on Page 2.
 (2) Derate as shown in Figure 1.
 (3) Pulse Test: Pulse Width = 300 μs , Duty Cycle = 2.0%.

STANDARD RECOVERY POWER RECTIFIERS

100-1000 VOLTS
3 AMPERE

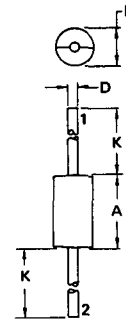

STYLE 1:
PIN 1, CATHODE
2, ANODE

DIM	MILLIMETERS		INCHES	
	MIN	MAX	MIN	MAX
A	9.40	9.65	0.370	0.380
B	4.83	5.33	0.190	0.210
D	1.22	1.32	0.048	0.052
K	26.97	27.23	1.062	1.072

CASE 267-01

MECHANICAL CHARACTERISTICS

Case: Void Free, Transfer Molded
 Finish: External Leads are Plated,
 Leads are readily Solderable
 Polarity: Indicated by Cathode Band
 Weight: 1.1 Grams (Approximately)
 Maximum Lead Temperature for
 Soldering Purposes:
 300 $^\circ\text{C}$, 1/8" from case for 10 s
 at 5.0 lb. tension

NOTE 1: DETERMINING MAXIMUM RATINGS

Reverse power dissipation and the possibility of thermal runaway must be considered when operating this rectifier at reverse voltages above 200 volts. Proper derating may be accomplished by use of equation (1):

$$T_{A(max)} = T_{J(max)} - R_{\theta JA} P_{F(AV)} - R_{\theta JA} P_{R(AV)} \quad (1)$$

where

$T_{A(max)}$ = Maximum allowable ambient temperature

$T_{J(max)}$ = Maximum allowable junction temperature (175°C or the temperature at which thermal runaway occurs, whichever is lowest.)

$P_{F(AV)}$ = Average forward power dissipation

$P_{R(AV)}$ = Average reverse power dissipation

$R_{\theta JA}$ = Junction-to-ambient thermal resistance

Figure 1 permits easier use of equation (1) by taking reverse power dissipation and thermal runaway into consideration. The figure solves for a reference temperature as determined by equation (2):

$$T_R = T_{J(max)} - R_{\theta JA} P_{R(AV)} \quad (2)$$

Substituting equation (2) into equation (1) yields:

$$T_{A(max)} = T_R - R_{\theta JA} P_{F(AV)} \quad (3)$$

Inspection of equations (2) and (3) reveals that T_R is the ambient temperature at which thermal runaway occurs or where $T_J = 175^\circ\text{C}$,

when forward power is zero. The transition from one boundary condition to the other is evident on the curves of Figure 1 as a difference in the rate of change of the slope in the vicinity of 165°C. The data of Figure 1 is based upon dc conditions. For use in common rectifier circuits, Table 1 indicates suggested factors for an equivalent dc voltage to use for conservative design; i.e.:

$$V_{R(equiv)} = V_{in(PK)} \times F \quad (4)$$

The Factor F is derived by considering the properties of the various rectifier circuits and the rectifiers reverse characteristics.

Example: Find $T_{A(max)}$ for MR510 operated in a 400 Volt dc supply using a full wave center-tapped circuit with capacitive filter such that $I_{DC} = 6.0 \text{ A}$, $(I_{F(AV)} = 3.0 \text{ A})$, $I_{(PK)}/I_{(AV)} = 10$, Input Voltage = 283 V(rms) (line to center tap), $R_{\theta JA} = 28^\circ\text{C/W}$.

- Step 1: Find $V_{R(equiv)}$. Read $F = 1.11$ from Table 1. ∴ $V_{R(equiv)} = 1.41(283)(1.11) = 444 \text{ V}$
- Step 2: Find T_R from Figure 1. Read $T_R = 167^\circ\text{C}$ @ $V_R = 444 \text{ V}$ & $R_{\theta JA} = 28^\circ\text{C/W}$.
- Step 3: Find $P_{F(AV)}$ from Figure 8. Read $P_{F(AV)} = 4 \text{ W}$ @ $\frac{I_{PK}}{I_{AV}} = 10$ & $I_{F(AV)} = 3.0 \text{ A}$
- Step 4: Find $T_{A(max)}$ from equation (3). $T_{A(max)} = 167 - (28)(4) = 55^\circ\text{C}$.

TABLE I – VALUES FOR FACTOR F

Circuit	Half Wave		Full Wave, Bridge		Full Wave Center-Tapped*†	
	Resistive	Capacitive*	Resistive	Capacitive	Resistive	Capacitive
Sine Wave	0.45	1.11	0.45	0.55	0.90	1.11
Square Wave	0.61	1.22	0.61	0.61	1.22	1.22

*Note that $V_{R(PK)} \approx 2 V_{in(PK)}$

†Use line to center tap voltage for V_{in} .

FIGURE 1 – MAXIMUM REFERENCE TEMPERATURE

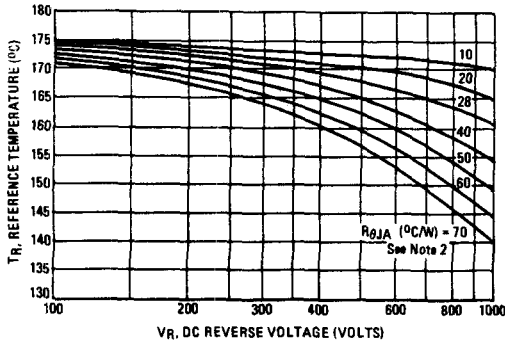
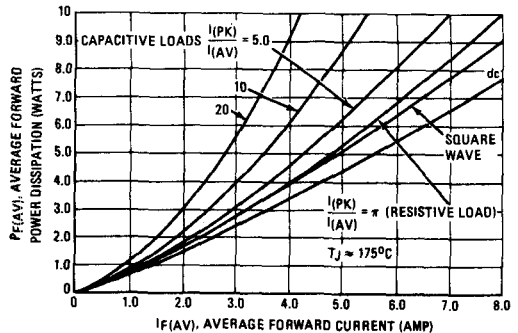

FIGURE 2 – FORWARD POWER DISSIPATION



CURRENT DERATING
(Reverse Power Loss Neglected)

FIGURE 3 – PC BOARD MOUNTING

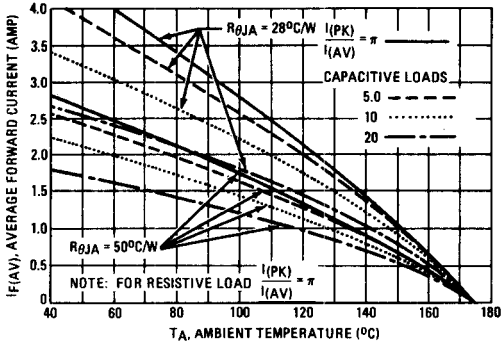

FIGURE 4 – SEVERAL LEAD LENGTHS

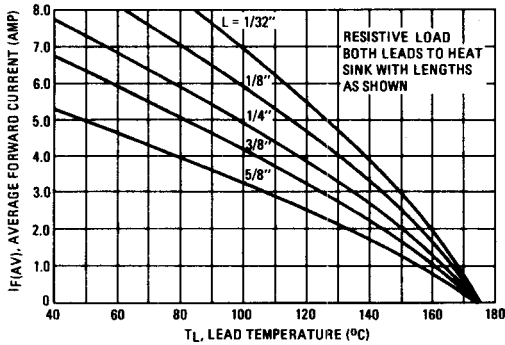

FIGURE 5 – 1/8" LEAD LENGTH

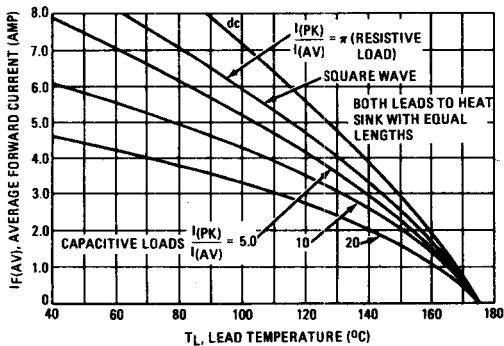

FIGURE 6 – FORWARD VOLTAGE

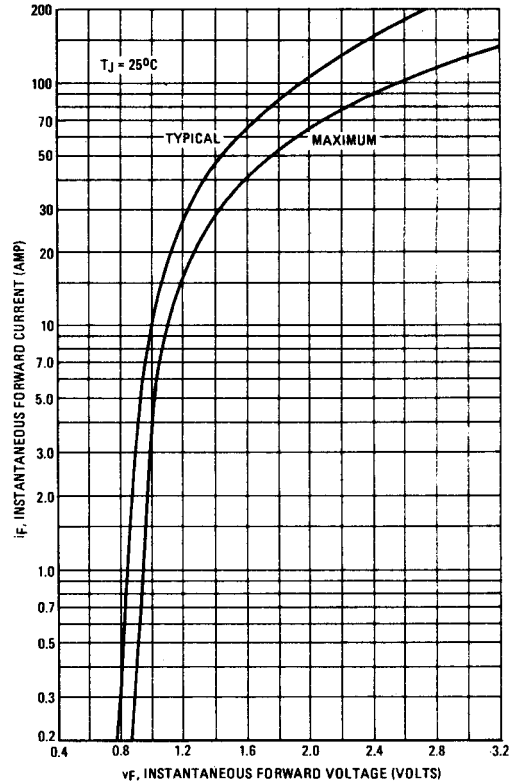

FIGURE 7 – FORWARD VOLTAGE TEMPERATURE COEFFICIENT

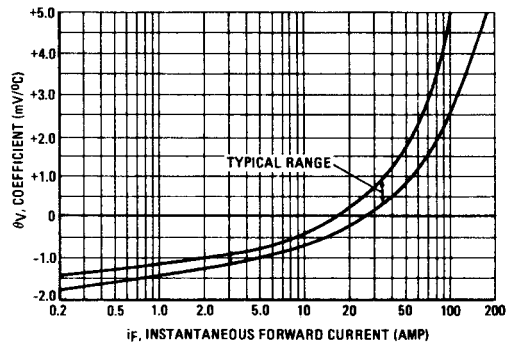

FIGURE 8 – MAXIMUM SURGE CAPABILITY

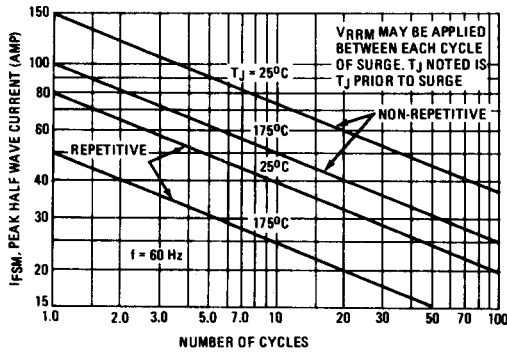
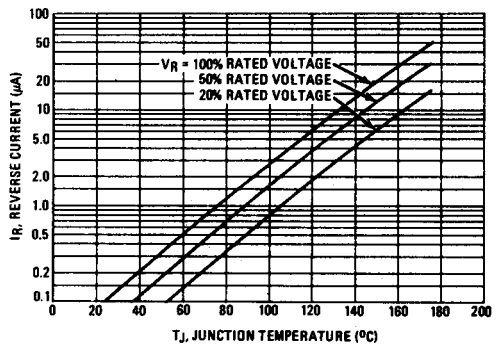

FIGURE 9 – TYPICAL REVERSE CURRENT



Thermal Characteristics

FIGURE 10 – THERMAL RESPONSE

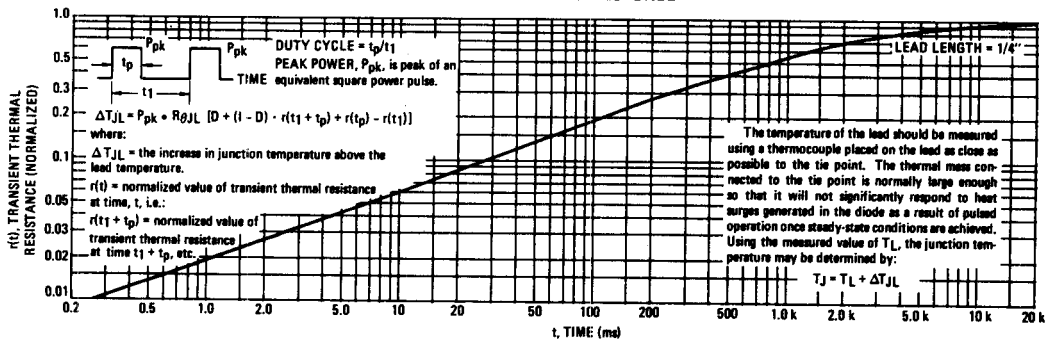
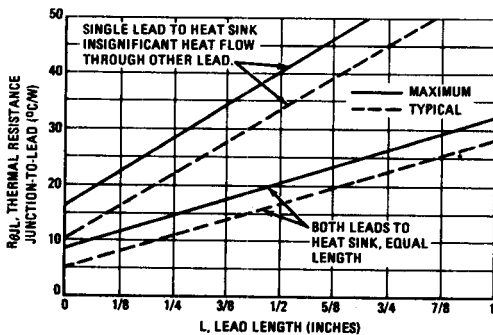

FIGURE 11 – STEADY-STATE THERMAL RESISTANCE



NOTE 2 – AMBIENT MOUNTING DATA

Data shown for thermal resistance junction-to-ambient ($R_{\theta JA}$) for the mountings shown is to be used as typical guideline values for preliminary engineering or in case the tie point temperature cannot be measured.

TYPICAL VALUES FOR $R_{\theta JA}$ IN STILL AIR

MOUNTING METHOD	LEAD LENGTH, L (IN)				$R_{\theta JA}$
	1/8	1/4	1/2	3/4	
1	50	51	53	56	$^\circ C/W$
2	56	59	61	63	$^\circ C/W$
3	28				$^\circ C/W$

MOUNTING METHOD 1

P.C. Board Where Available Copper Surface area is small.

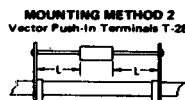
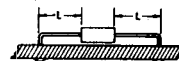

MOUNTING METHOD 3

P.C. Board with 1-1/2" x 1-1/2" Copper Surface

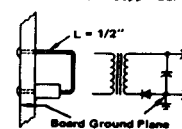
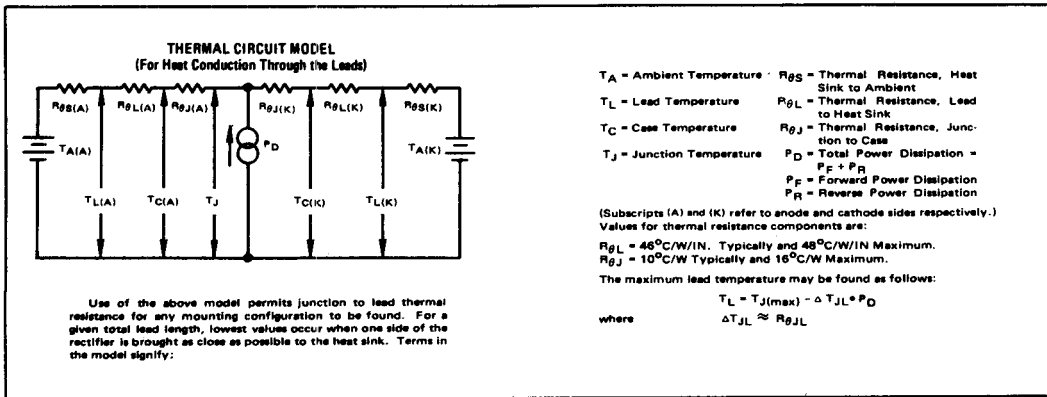

FIGURE 12 – APPROXIMATE THERMAL CIRCUIT MODEL



TYPICAL DYNAMIC CHARACTERISTICS
($T_J = 25^\circ\text{C}$)

FIGURE 13 – FORWARD RECOVERY TIME

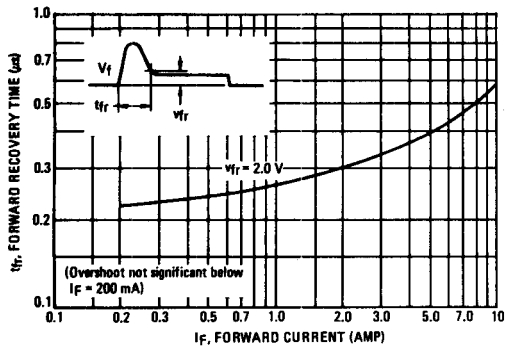

FIGURE 14 – REVERSE RECOVERY TIME

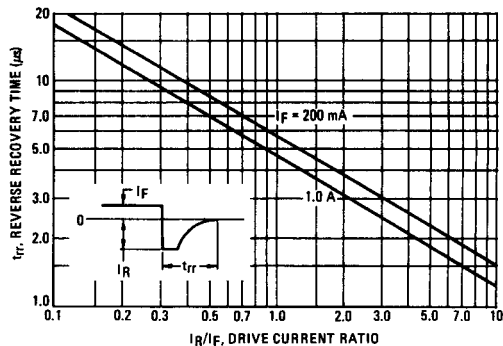

FIGURE 15 – RECTIFICATION WAVEFORM EFFICIENCY

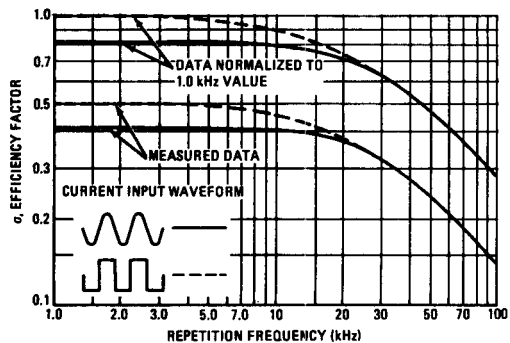
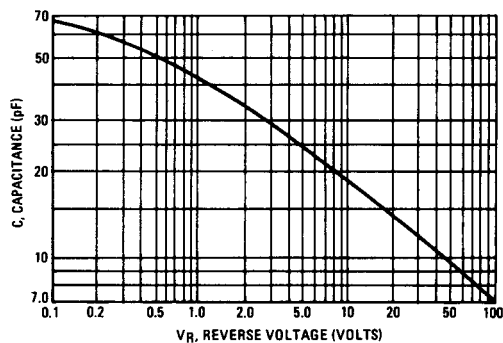
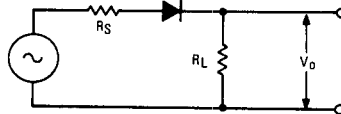

FIGURE 16 – JUNCTION CAPACITANCE



RECTIFIER EFFICIENCY NOTE

FIGURE 17 – SINGLE-PHASE HALF-WAVE RECTIFIER CIRCUIT



The rectification efficiency factor σ shown in Figure 15 was calculated using the formula:

$$\sigma = \frac{P_{(dc)}}{P_{(rms)}} = \frac{\frac{V_o^2(dc)}{R_L}}{\frac{V_o^2(rms)}{R_L}} \cdot 100\% = \frac{V_o^2(dc)}{V_o^2(ac) + V_o^2(dc)} \cdot 100\% \quad (1)$$

For a sine wave input $V_m \sin(\omega t)$ to the diode, assumed lossless, the maximum theoretical efficiency factor becomes:

$$\sigma_{(sine)} = \frac{\frac{V_m^2}{\pi^2 R_L}}{\frac{V_m^2}{4R_L}} \cdot 100\% = \frac{4}{\pi^2} \cdot 100\% = 40.6\% \quad (2)$$

For a square wave input of amplitude V_m , the efficiency factor becomes:

$$\sigma_{(square)} = \frac{\frac{V_m^2}{2R_L}}{\frac{V_m^2}{R_L}} \cdot 100\% = 50\% \quad (3)$$

(A full wave circuit has twice these efficiencies)

As the frequency of the input signal is increased, the reverse recovery time of the diode (Figure 14) becomes significant, resulting in an increasing ac voltage component across R_L which is opposite in polarity to the forward current, thereby reducing the value of the efficiency factor σ , as shown on Figure 15.

It should be emphasized that Figure 15 shows waveform efficiency only; it does not provide a measure of diode losses. Data was obtained by measuring the ac component of V_o with a true rms ac voltmeter and the dc component with a dc voltmeter. The data was used in Equation 1 to obtain points for the figure.