

DUAL HIGH SPEED VOLTAGE COMPARATOR

The KA219 is a dual high speed voltage comparator designed to operate from a single +5V supply up to $\pm 15V$ dual supplies. Open collector of the output stage makes the KA219 compatible with RTL, DTL and TTL as well as capable of driving lamps and relays at currents up to 25mA. Typical response time of 80ns with $\pm 15V$ power supplies makes the KA219 ideal for application in fast A/D converts, level shifters, oscillators, and multivibrators.

FEATURES

- Operates from a single 5V supply
- Typically 80ns response time at $\pm 15V$
- Open collector outputs : up to +35V
- High output drive current : 25mA
- Inputs and outputs can be isolated from system ground
- Minimum fan-out of 2 (each side)
- Two independent comparators

BLOCK DIAGRAM

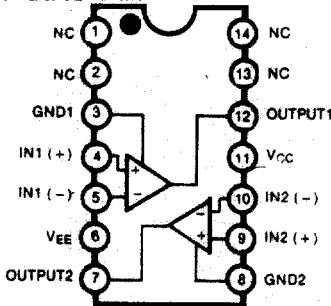

ORDERING INFORMATION

Device	Package	Operating Temperature
KA319	14 DIP	0 ~ + 70°C
KA319D	14 SOP	
KA219	14 DIP	-25 ~ + 85°C
KA219D	14 SOP	

SCHEMATIC DIAGRAM

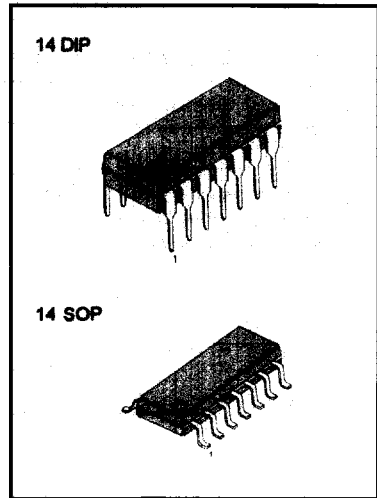
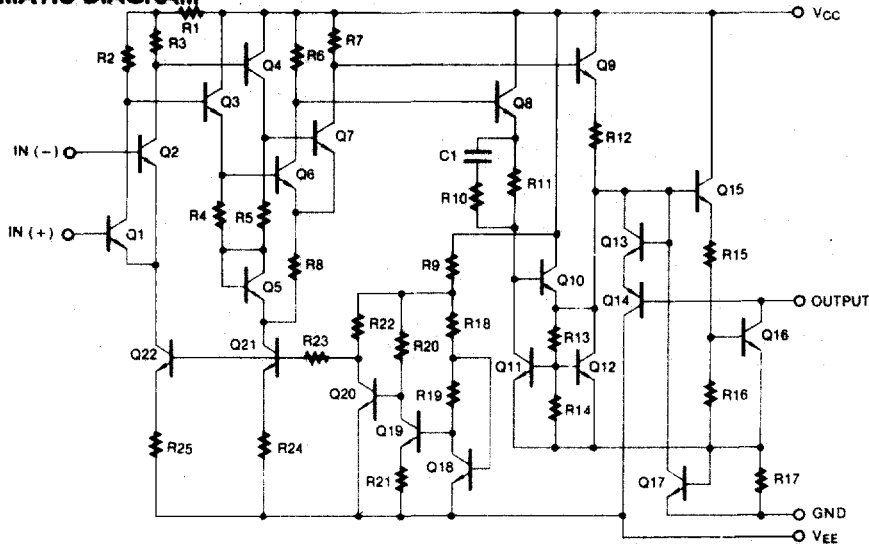

ABSOLUTE MAXIMUM RATINGS

Characteristic	Symbol	Value	Unit
Supply Voltage	V_{CC}	36	V
Output to Negative Supply Voltage	$V_O - V_{EE}$	36	V
Ground to Negative Supply Voltage	V_{EE}	25	V
Ground to Positive Supply Voltage	V_{CC}	18	V
Differential Input Voltage	$V_{I(DIFF)}$	± 5	V
Input Voltage	V_I	± 15	V
Output Short Circuit Duration		10	sec
Power Dissipation	P_D	500	mW
Operating Temperature Range KA219	T_{OPR}	-25 ~ + 85	$^{\circ}C$
KA319		0 ~ + 70	
Storage Temperature Range	T_{STG}	-65 ~ + 150	$^{\circ}C$

ELECTRICAL CHARACTERISTICS

($V_{CC} = +15V$, $V_{EE} = -15V$, $T_A = 25^{\circ}C$, unless otherwise specified)

Characteristic	Symbol	Test Conditions	KA219			KA319			Unit
			Min	Typ	Max	Min	Typ	Max	
Input Offset Voltage (Note 1)	V_{IO}	$R_B \leq 5K\Omega$ Note 3		0.7	4.0		2.0	8.0	mV
Input Offset Current (Note 1)	I_{IO}	Note 3		10	75		10	200	nA
Input Bias Current	I_{BIAS}	Note 3		150	500		150	1000	nA
Voltage Gain	G_V		10	40		8	40		V/mV
Response Time (Note 2)	t_{RES}	$V_{CC} = \pm 15V$		80			80		ns
Saturation Voltage	V_{SAT}	$V_I \leq -5mV$, $I_O = 25mA$		0.6	1.5				V
		$V_I \leq -5mV$, $I_O = 25mA$					0.6	1.5	V
		$V_{CC} \geq 4.5V$, $V_{EE} = 0V$		0.23	0.4				V
		$V_I \leq -8mV$, $I_{SINK} \leq 3.2mA$							V
		$V_I \leq -5mV$, $I_O = 25mA$					0.3	0.4	V
Output Leakage Current	$I_{O(LKG)}$	$V_I \geq 5mV$, $V_{OP} = 35V$ Note 3		0.2	2				μA
		$V_I \geq 10mV$, $V_{OP} = 35V$		1	10				μA
		$V_I \geq 10mV$, $V_{OP} = 35V$					0.2	10	μA
Input Voltage Range	$V_{(IR)}$	Note 3		± 13			± 13		V
		$V_{CC} = \pm 15V$ $V_{CC} = 5V$, $V_{EE} = 0V$	1		3	1		3	

ELECTRICAL CHARACTERISTICS

(V_{CC} = +15V, V_{EE} = -15V, T_A = 25°C, unless otherwise specified)

Characteristic	Symbol	Test Conditions	KA219			KA319			Unit
			Min	Typ	Max	Min	Typ	Max	
Differential Input Voltage	V _(DIFF)		±5			±5			V
Positive Supply Current	I _{CC1}	V _{CC} = 5V, V _{EE} = 0V		3.6			3.6		mA
Positive Supply Current	I _{CC2}	V _{CC} = ±15V		7.5	11.5		7.5	12.5	mA
Negative Supply Current	I _{EE}	V _{CC} = ±15V		3	4.5		3	5	mA

Note 1. The offset voltage and offset currents given are the maximum values required to drive the output within a volt of either supply with a 1mA load. Thus, these parameters define an error band and take into account the worst case effects of voltage gain and input impedance.

2. The response time specified is for a 100mV input step with 5mV overdrive.

3. KA319 : 0 ≤ T_A ≤ +70°C

KA219 : -25 ≤ T_A ≤ +85°C

6

TYPICAL PERFORMANCE CHARACTERISTICS

Fig. 1 INPUT CURRENT

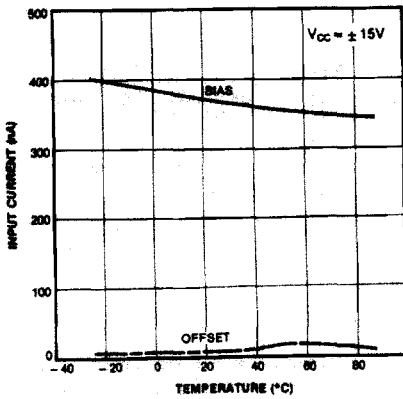

Fig. 2 OUTPUT SATURATION VOLTAGE

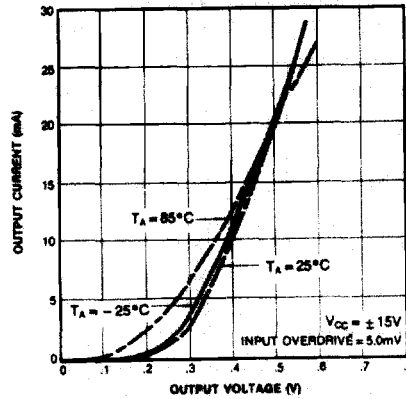

Fig. 3 TRANSFER FUNCTION

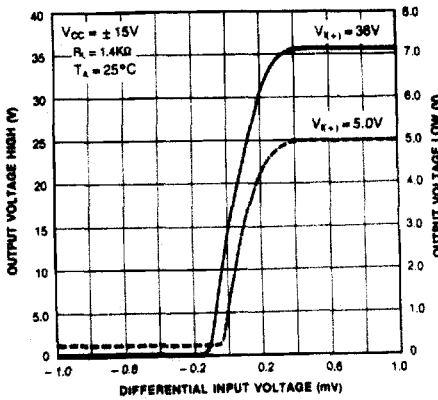

Fig. 4 RESPONSE TIME FOR VARIOUS INPUT OVERDRIVE

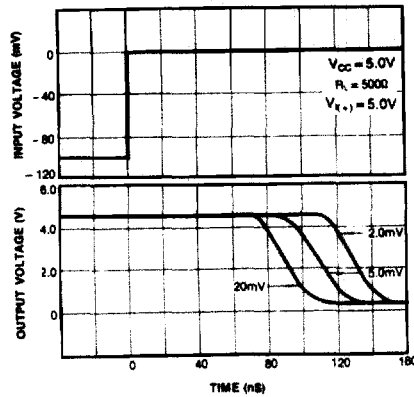

Fig. 5 RESPONSE TIME FOR VARIOUS INPUT OVERDRIVE

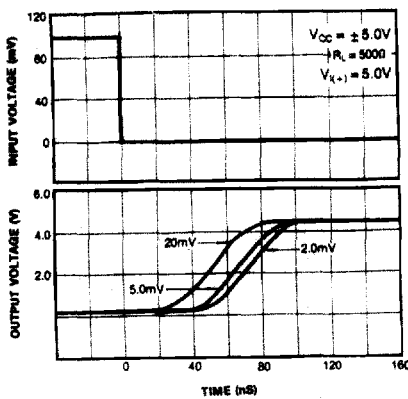

Fig. 6 INPUT CHARACTERISTICS

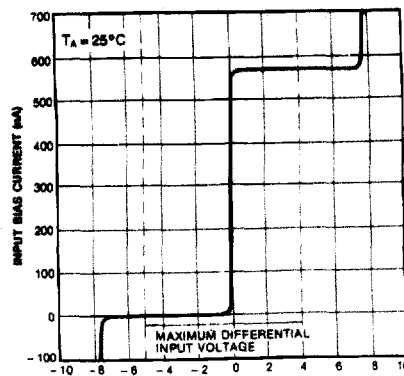

Fig. 7 RESPONSE TIME FOR VARIOUS INPUT OVERDRIVER

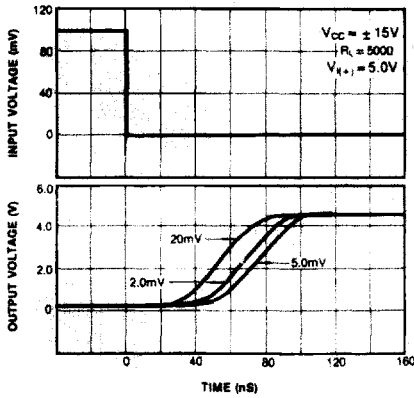

Fig. 8 RESPONSE TIME FOR VARIOUS INPUT OVERDRIVER

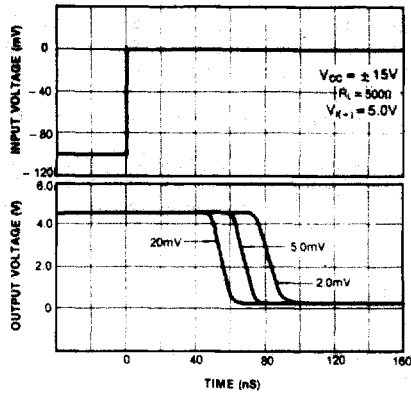

Fig. 9 SUPPLY CURRENT

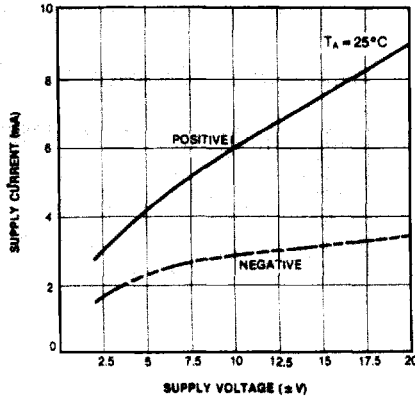

Fig. 10 SUPPLY CURRENT

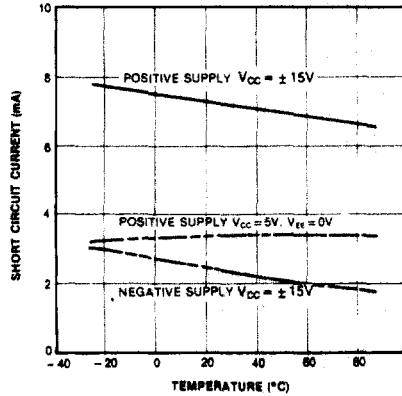

Fig. 11 COMMON MODE LIMITS

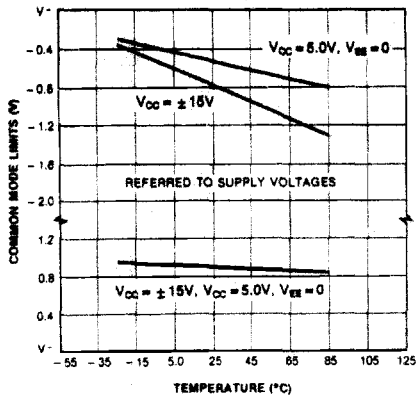
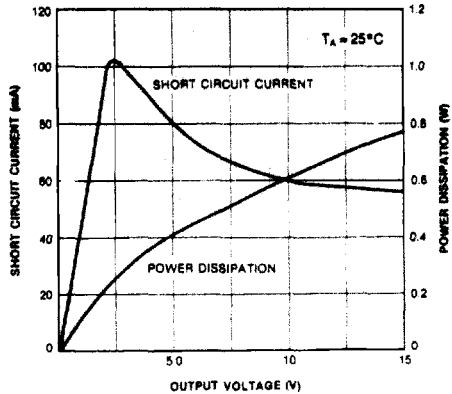

Fig. 12 OUTPUT LIMITING CHARACTERISTICS



6