

Metal Oxide Varistor : TVR-V Series



Disc Type Varistor for Surge Protection (Medium Surge Series)

■ Features

1. RoHS compliant
2. Halogen-free series are available
3. Body size: $\Phi 10$ and $\Phi 14$ mm
4. Wide operating voltage range: 130Vac ~ 680Vac
5. Operating temperature range: $-40^{\circ}\text{C} \sim +85^{\circ}\text{C}$
Storage temperature range : $-40^{\circ}\text{C} \sim +125^{\circ}\text{C}$
6. Agency recognition: UL 1449 3rd/cUL/VDE
7. Meet IEC 60950-1 Annex Q requirement

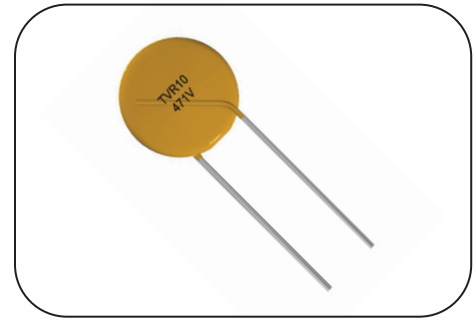

■ Recommended Applications

1. Power supply
2. Home appliance
3. Industrial equipment
4. Telecommunication or telephone system
5. Smart meter
6. PLC (Power line communication)
7. Lighting products
8. Photovoltaic industry

Note: V of the marking stands for TVR-V series

■ Part Number Code

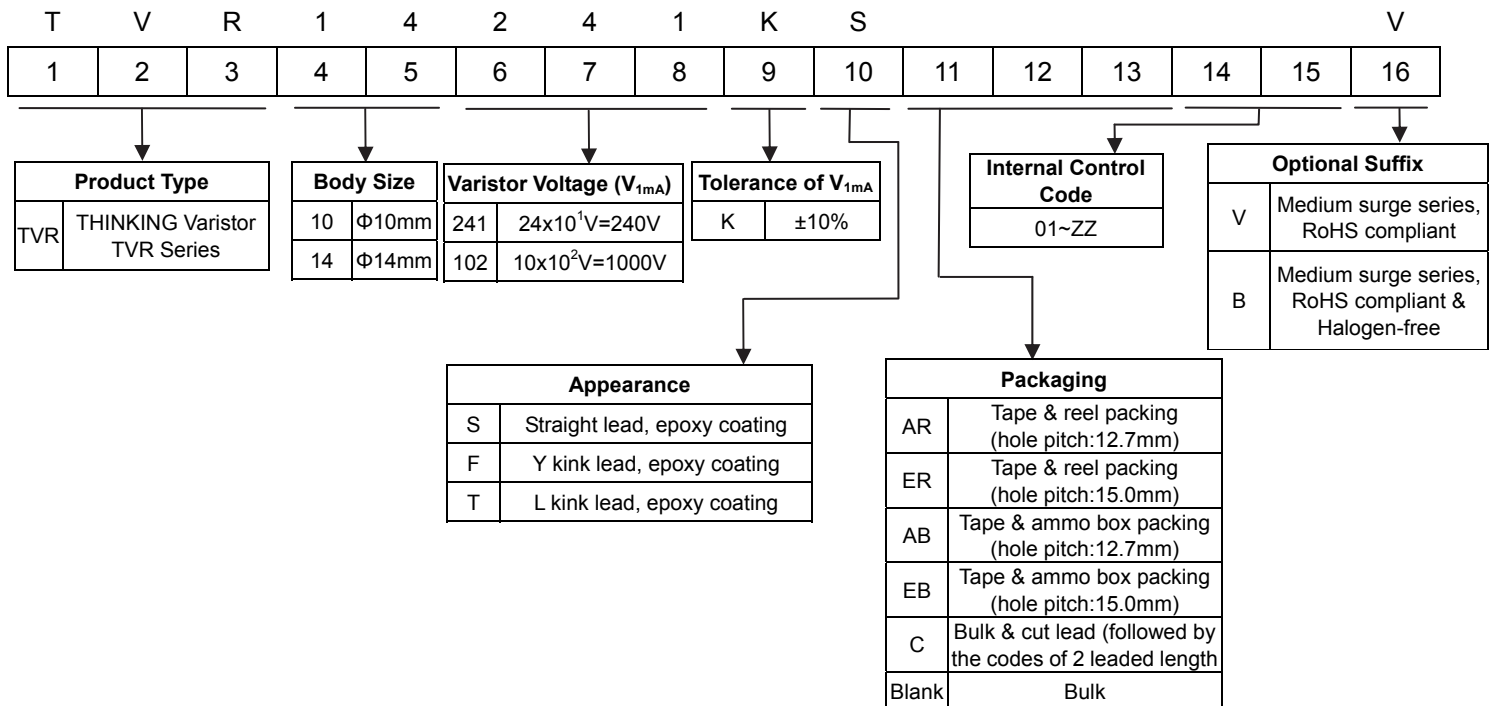

Note: Optional suffix will be the 11th digit if packaging and internal control codes are not coded.

Metal Oxide Varistor : TVR-V Series



Disc Type Varistor for Surge Protection (Medium Surge Series)

■ Structure and Dimensions

● S Type (Straight lead)

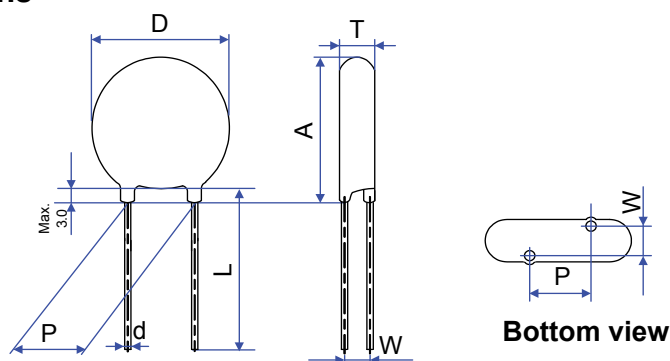

(Unit: mm)

Series	D	Lmin.	d	P	Amax.	Tmax.	W
TVR10-V	9.5~12.5	26.5	0.8±0.02	7.5±1	15.0	Please refer to Electrical Characteristics Table	
TVR14-V	13.5~16.0	26.5	0.8±0.02	7.5±1	18.5 (for TVR14201-511-V) 19.0 (for TVR14561-112-V)		

● F Type (Y kink lead)

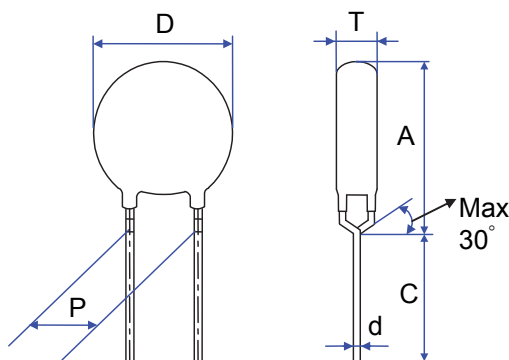

(Unit: mm)

Series	D	Cmin.	d	P	Amax.	Tmax.
TVR10-V	9.5~12.5	20	0.8±0.02	7.5±1	16.0	Please refer to Electrical Characteristics Table
TVR14-V	13.5~16.0	20	0.8±0.02	7.5±1	19.0	

● T Type (L kink lead)

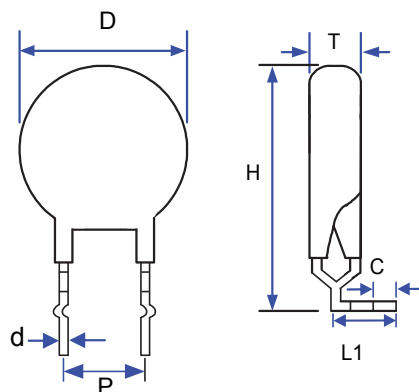

(Unit: mm)

Series	D	Cmin.	d	P	Hmax.	L1	Tmax.
TVR10-V	9.5~12.5	3.8±0.8	0.8±0.02	7.5±1	20.0	7.0±1	Please refer to Electrical Characteristics Table
TVR14-V	13.5~16.0			7.5±1	23.5	7.0±1	

Metal Oxide Varistor : TVR-V Series



Disc Type Varistor for Surge Protection (Medium Surge Series)

■ Electrical Characteristics

10-V Series

Part No.	Varistor Voltage (@ 1mA DC)	Max. Continuous Voltage		Max. Clamping Voltage (8/20μs)		Max. Surge Current (8/20μs)	Rated Power	Max. Energy (10/1000μs)	Reference Capacitance @1KHz	Dimension			UL 1449 3 rd SPD Application
	V _{1mA}	V _{AC(rms)}	V _{DC}	V _P	I _P	I _{max}	P	W _{max}	C _p	T _{min}	T _{max}	W ±1.0	
	(V)	(V)	(V)	(V)	(A)	(A)	(W)	(J)	(pF)	(mm)			
TVR10201-V	200 (180~220)	130	170	340	25	3500	0.4	35	570	2.9	4.4	1.7	For SPD Type 3 Application
TVR10221-V	220 (198~242)	140	180	360	25	3500	0.4	39	520	3.0	4.5	1.7	
TVR10241-V	240 (216~264)	150	200	395	25	3500	0.4	42	480	3.1	4.6	1.8	
TVR10271-V	270 (243~297)	175	225	455	25	3500	0.4	49	425	3.3	5.0	1.9	
TVR10301-V	300 (270~330)	195	250	500	25	3500	0.4	53	380	3.5	5.3	2.1	
TVR10331-V	330 (297~363)	215	275	550	25	3500	0.4	58	350	3.8	5.7	2.2	
TVR10361-V	360 (324~396)	230	300	595	25	3500	0.4	65	320	4.0	6.0	2.3	
TVR10391-V	390 (351~429)	250	320	650	25	3500	0.4	70	295	4.2	6.2	2.5	
TVR10431-V	430 (387~473)	275	350	710	25	3500	0.4	80	260	4.3	6.5	2.5	
TVR10471-V	470 (423~517)	300	385	775	25	3500	0.4	85	240	4.4	6.6	2.6	
TVR10511-V	510 (459~561)	320	410	845	25	3500	0.4	92	220	4.6	6.8	2.8	
TVR10561-V	560 (504~616)	350	450	930	25	3500	0.4	92	200	4.7	7.1	3.0	
TVR10621-V	620 (558~682)	395	510	1020	25	3500	0.4	95	180	4.8	7.2	3.2	
TVR10681-V	680 (612~748)	420	560	1120	25	3500	0.4	98	175	4.9	7.4	3.4	
TVR10751-V	750 (675~825)	465	615	1235	25	3500	0.4	100	160	5.1	7.6	3.7	
TVR10821-V	820 (738~902)	510	670	1355	25	3500	0.4	110	150	5.2	7.8	3.4	
TVR10911-V	910 (819~1001)	550	745	1500	25	3500	0.4	130	130	5.3	8.0	3.7	
TVR10102-V	1000 (900~1100)	625	825	1650	25	3500	0.4	140	120	5.3	8.3	4.0	
TVR10112-V	1100 (990~1210)	680	895	1815	25	3500	0.4	155	110	5.7	8.6	4.3	

Metal Oxide Varistor : TVR-V Series



Disc Type Varistor for Surge Protection (Medium Surge Series)

14-V Series

Part No.	Varistor Voltage (@ 1mA DC)	Max. Continuous Voltage		Max. Clamping Voltage (8/20µs)		Max. Surge Current (8/20µs)	Nominal Discharge Current ^{*1} (8/20µs)	Rated Power	Max. Energy (10/1000µs)	Reference Capacitance @1KHz	Dimension			UL 1449 3 rd SPD Type ^{*2}
	V _{1mA}	V _{AC(rms)}	V _{DC}	V _P	I _P	I _{max}	I _n	P	W _{max}	C _p	T _{min}	T _{max}	W ±1.0	
	(V)	(V)	(V)	(V)	(A)	(A)	(A)	(W)	(J)	(pF)	(mm)			
TVR14201-V	200 (180~220)	130	170	340	50	6000	3000	0.6	84	970	2.9	4.4	1.7	Type 5
TVR14221-V	220 (198~242)	140	180	360	50	6000	3000	0.6	91	880	3.0	4.5	1.7	
TVR14241-V	240 (216~264)	150	200	395	50	6000	3000	0.6	98	820	3.1	4.7	1.8	
TVR14271-V	270 (243~297)	175	225	455	50	6000	3000	0.6	112	720	3.3	4.9	1.9	
TVR14301-V	300 (270~330)	195	250	500	50	6000	3000	0.6	123	650	3.4	5.1	2.1	
TVR14331-V	330 (297~363)	215	275	550	50	6000	3000	0.6	133	600	3.5	5.3	2.2	
TVR14361-V	360 (324~396)	230	300	595	50	6000	3000	0.6	147	550	3.6	5.5	2.3	
TVR14391-V	390 (351~429)	250	320	650	50	6000	3000	0.6	161	500	3.7	5.6	2.5	
TVR14431-V	430 (387~473)	275	350	710	50	6000	3000	0.6	182	440	3.8	5.7	2.5	
TVR14471-V	470 (423~517)	300	385	775	50	6000	3000	0.6	196	400	3.9	5.9	2.6	
TVR14511-V	510 (459~561)	320	420	845	50	6000	3000	0.6	210	370	4.1	6.1	2.8	
TVR14561-V	560 (504~616)	350	460	930	50	6000	3000	0.6	231	340	4.2	6.4	3.0	
TVR14621-V	620 (558~682)	395	510	1020	50	6000	3000	0.6	252	300	4.5	6.7	3.2	
TVR14681-V	680 (612~748)	420	560	1120	50	6000	3000	0.6	266	290	4.7	7.1	3.4	
TVR14751-V	750 (675~825)	465	615	1235	50	6000	3000	0.6	280	270	5.0	7.5	3.7	
TVR14821-V	820 (738~902)	510	670	1355	50	6000	3000	0.6	280	250	5.2	7.9	3.4	
TVR14911-V	910 (819~1001)	550	745	1500	50	6000	3000	0.6	308	220	5.6	8.4	3.7	
TVR14102-V	1000 (900~1100)	625	825	1650	50	6000	3000	0.6	336	200	5.9	8.9	4.0	
TVR14112-V	1100 (990~1210)	680	895	1815	50	6000	3000	0.6	364	180	6.3	9.5	4.3	

Note:

*1: Nominal discharge current is the specification defined in UL 1449 3rd and use 8/20µs current waveform to test the varistor.



*2: SPD Type 5 also can be applied for SPD Type 2 application based on selecting suitable "Nominal Discharge Current" rating.

Metal Oxide Varistor : TVR-V Series



Disc Type Varistor for Surge Protection (Medium Surge Series)



■ Safety Approvals

Certified Model No.	Agency				
					
	UL1449 3 rd & cUL: E314979	5944	IEC60950-1 2 nd Annex Q	GB/T10193-1997 GB/T10194-1997 CQC10001041748 CQC10001041749	GB8898-2011 GB4943.1-2011 CQC10001041748 CQC10001041749
TVR10201-V	√	√	√	√	√
TVR10221-V	√	√	√	√	√
TVR10241-V	√	√	√	√	√
TVR10271-V	√	√	√	√	√
TVR10301-V	√	√	√	√	√
TVR10331-V	√	√	√	√	√
TVR10361-V	√	√	√	√	√
TVR10391-V	√	√	√	√	√
TVR10431-V	√	√	√	√	√
TVR10471-V	√	√	√	√	√
TVR10511-V	√	√	√	√	√
TVR10561-V	√	√	√	√	√
TVR10621-V	√	√	√	√	√
TVR10681-V	√	√	√	√	√
TVR10751-V	√	√	√	√	√
TVR10821-V	√	√	√	√	√
TVR10911-V	√	√	√	√	√
TVR10102-V	√	√	√	√	√
TVR10112-V	√	√	√	√	√

Metal Oxide Varistor : TVR-V Series



Disc Type Varistor for Surge Protection (Medium Surge Series)

Certified Model No.	Agency		
			
	UL1449 3 rd & cUL: E314979	5944	IEC60950-1 2 nd Annex Q
TVR14201-V	√	√	√
TVR14221-V	√	√	√
TVR14241-V	√	√	√
TVR14271-V	√	√	√
TVR14301-V	√	√	√
TVR14331-V	√	√	√
TVR14361-V	√	√	√
TVR14391-V	√	√	√
TVR14431-V	√	√	√
TVR14471-V	√	√	√
TVR14511-V	√	√	√
TVR14561-V	√	√	√
TVR14621-V	√	√	√
TVR14681-V	√	√	√
TVR14751-V	√	√	√
TVR14821-V	√	√	√
TVR14911-V	√	√	√
TVR14102-V	√	√	√
TVR14112-V	√	√	√

Metal Oxide Varistor : TVR-V Series



Disc Type Varistor for Surge Protection (Medium Surge Series)

Power Derating Curve

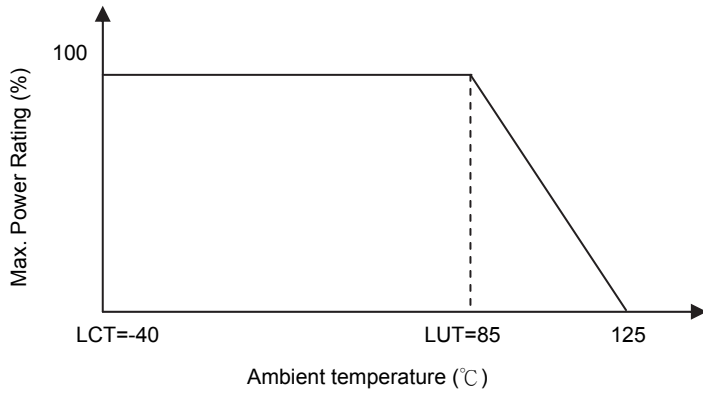

Surge Current Standard Waveform

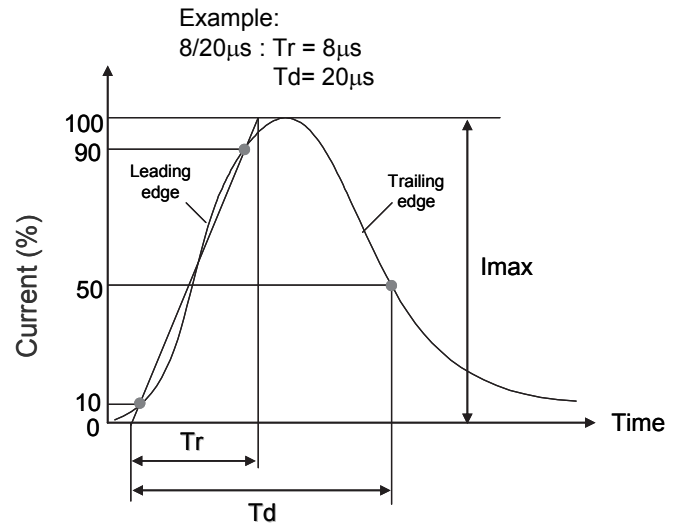

Max. Surge Current Derating Curves

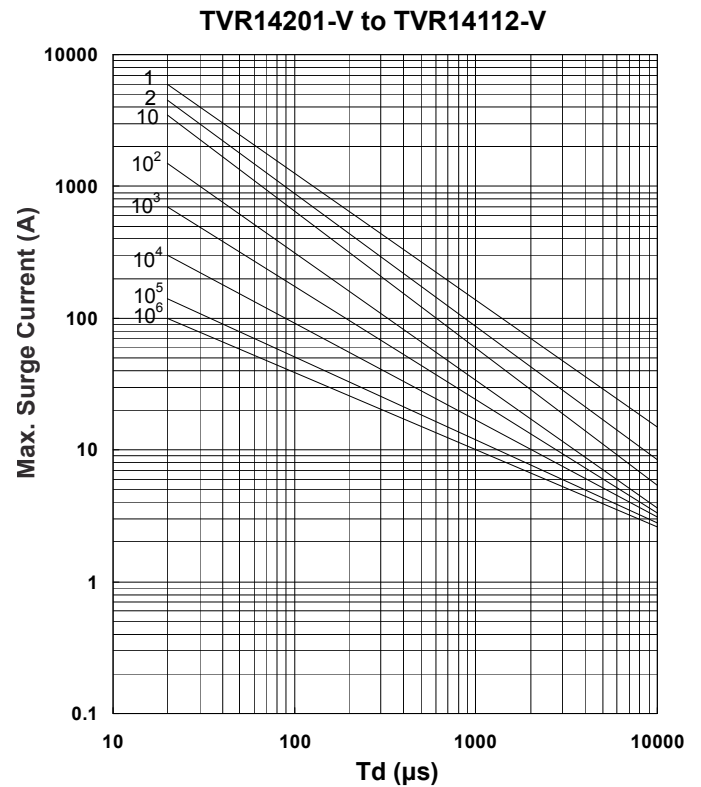
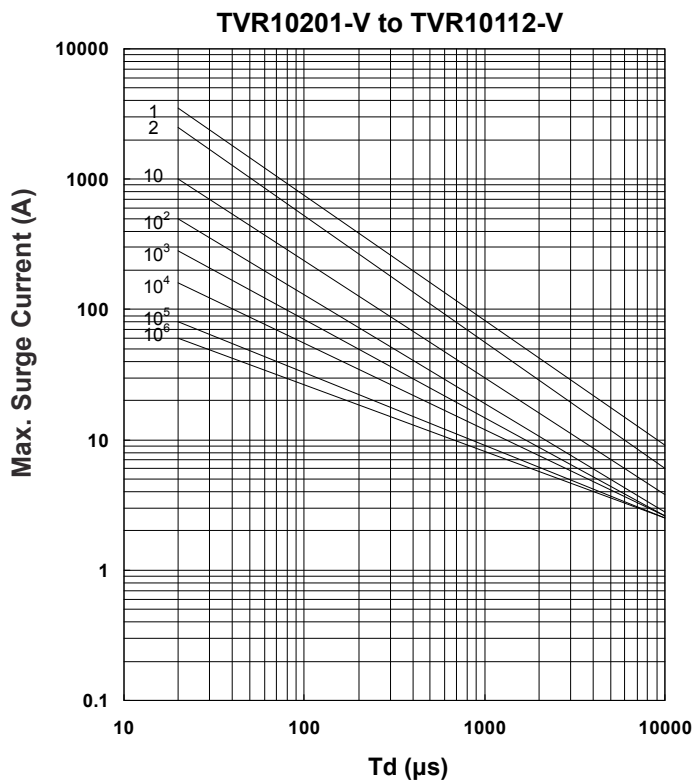

Metal Oxide Varistor : TVR-V Series



Disc Type Varistor for Surge Protection (Medium Surge Series)

■ Max. Leakage Current and Max. Clamping Voltage Curves

Max. Leakage Current and Max. Clamping Voltage Curves (TVR10201-V to TVR10621-V)

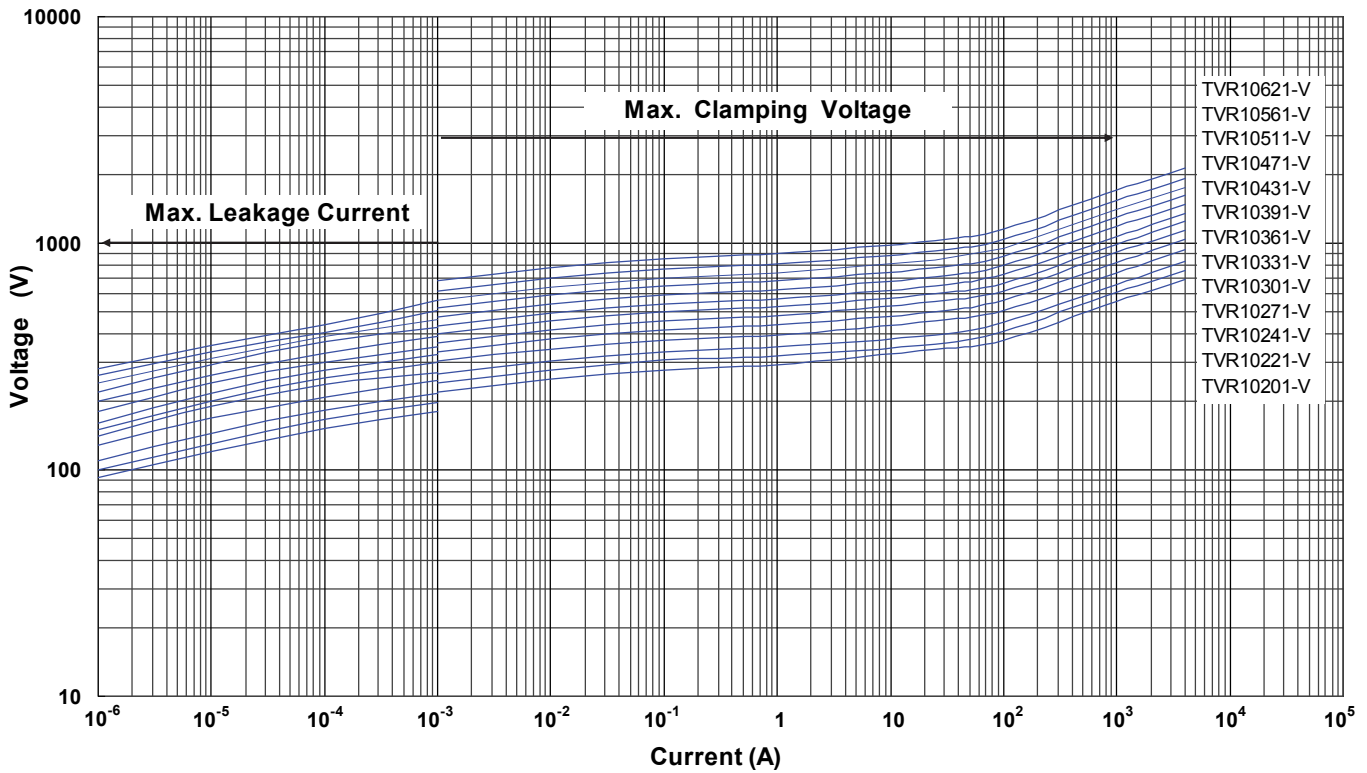

Max. Leakage Current and Max. Clamping Voltage Curves (TVR10681-V to TVR10112-V)

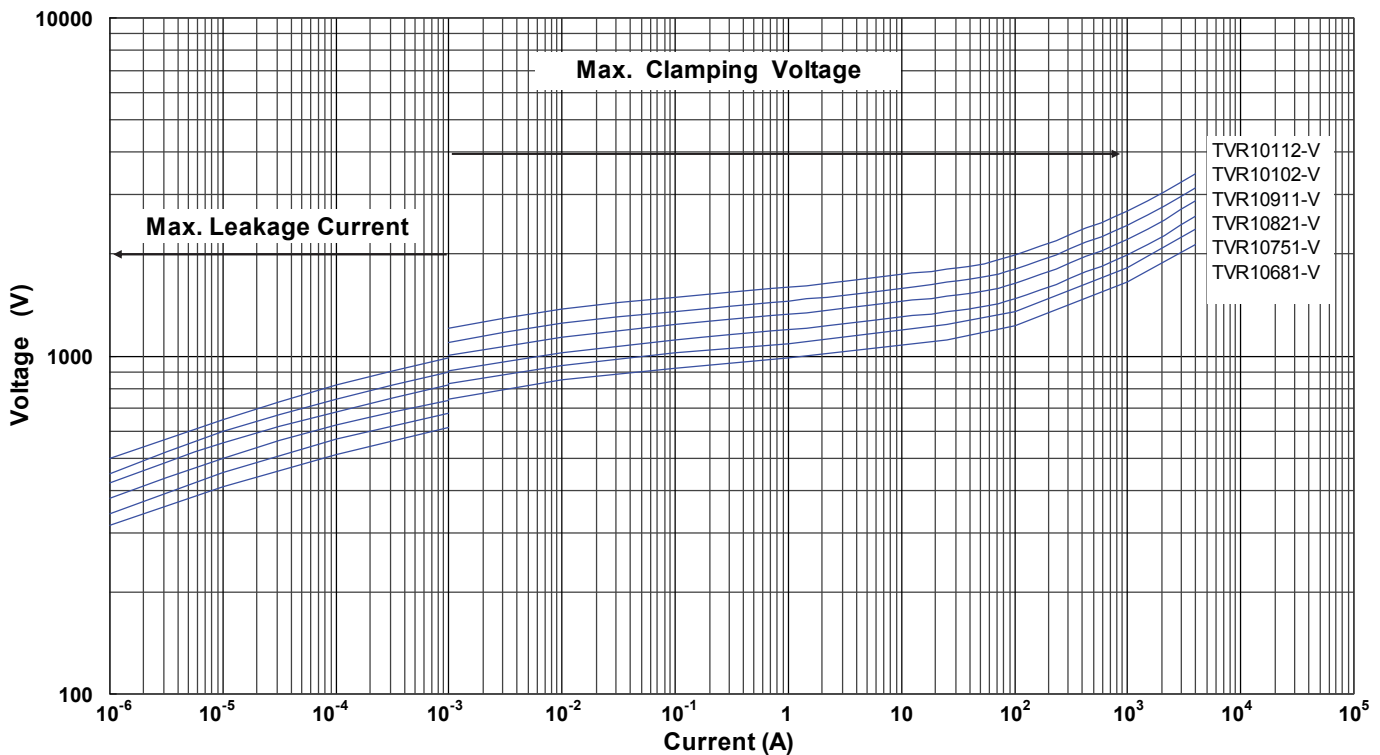

Metal Oxide Varistor : TVR-V Series



Disc Type Varistor for Surge Protection (Medium Surge Series)

■ Max. Leakage Current and Max. Clamping Voltage Curves

Max. Leakage Current and Max. Clamping Voltage Curves (TVR14201-V to TVR14471-V)

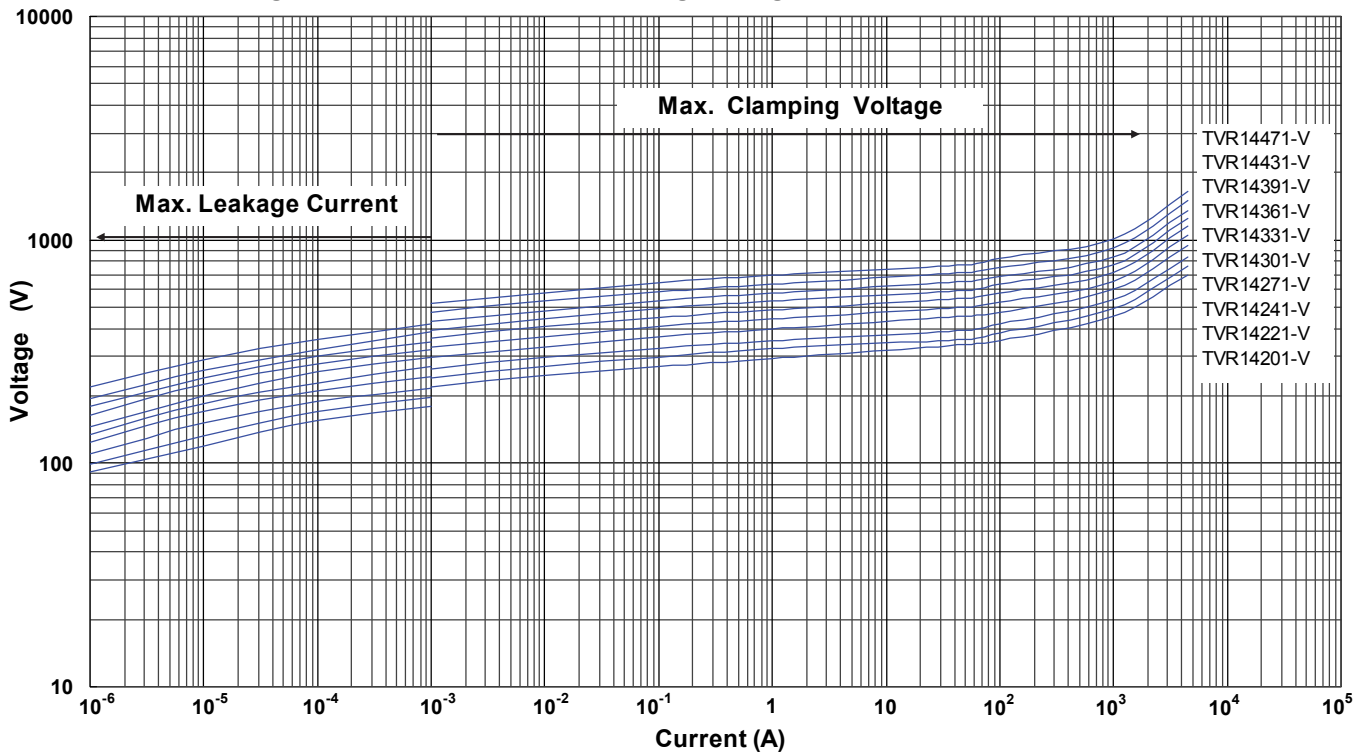

Max. Leakage Current and Max. Clamping Voltage Curves (TVR14511-V to TVR14112-V)

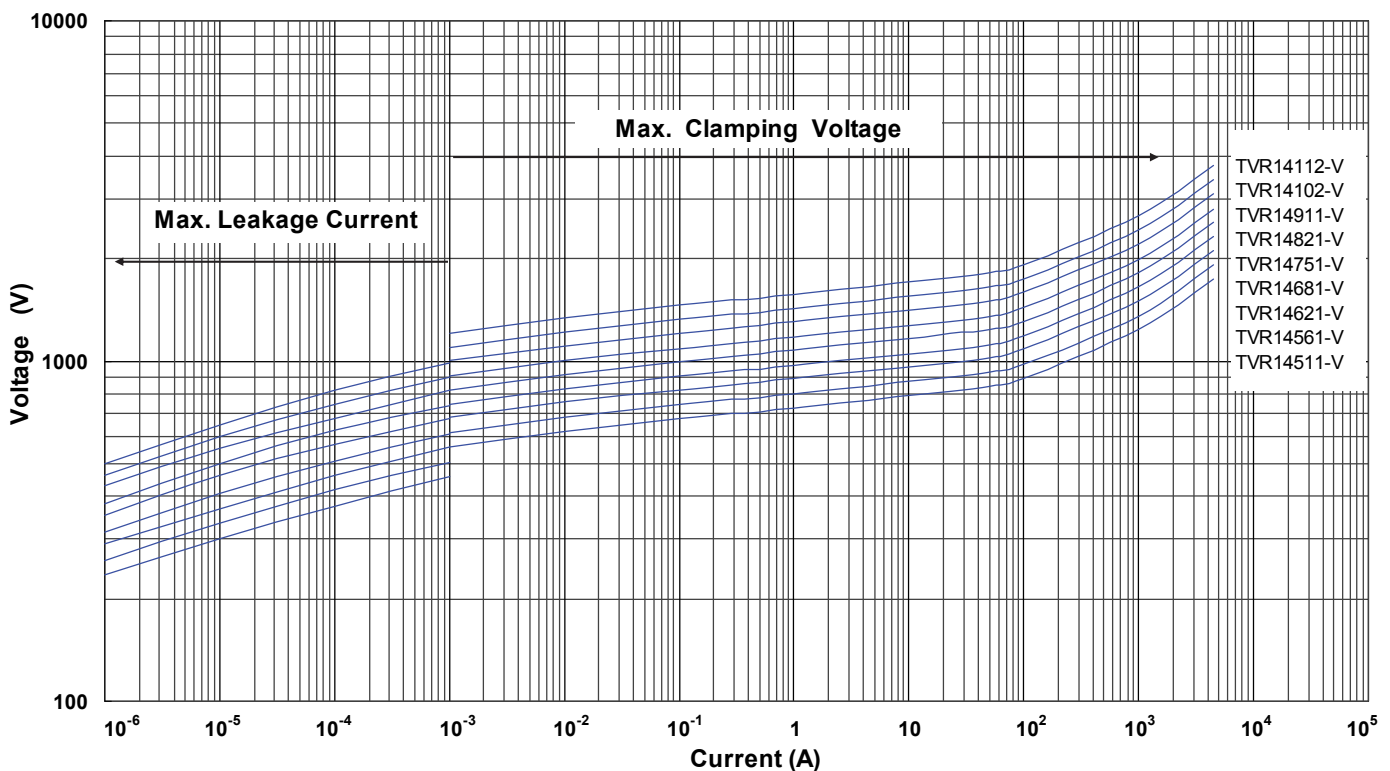

Metal Oxide Varistor : TVR-V Series



Disc Type Varistor for Surge Protection (Medium Surge Series)

■ Soldering Recommendation

● Wave Soldering Profile

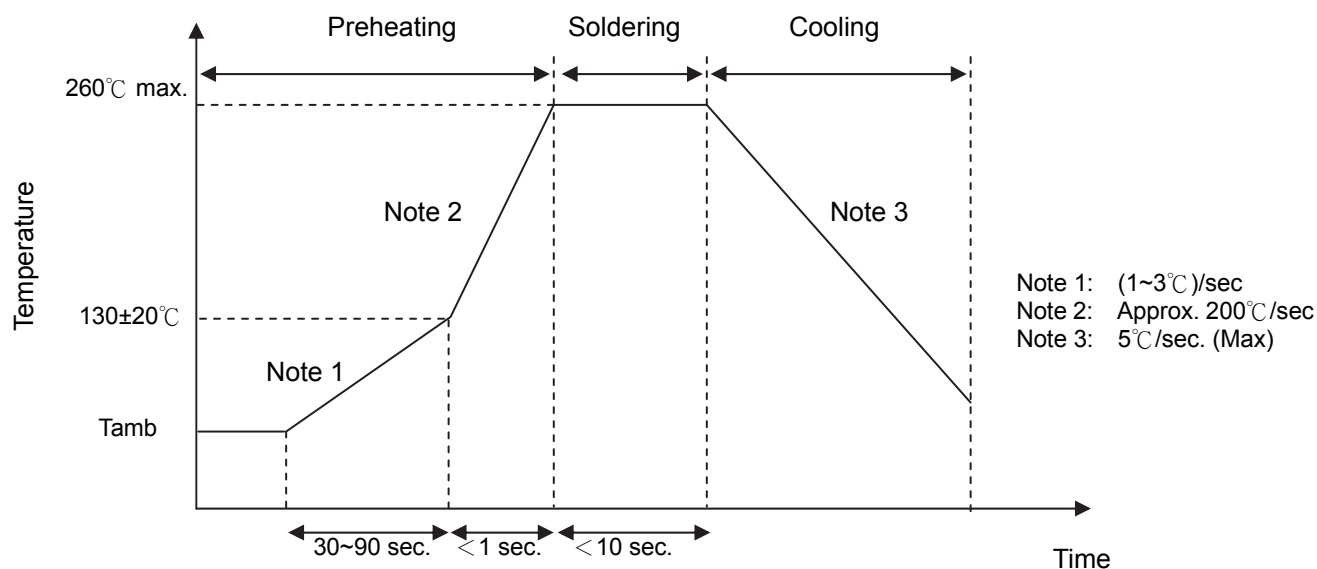

● Recommended Reworking Conditions with Soldering Iron

Item	Conditions
Temperature of Soldering Iron-tip	360°C (max.)
Soldering Time	3 sec (max.)
Distance from Varistor	2 mm (min.)

Metal Oxide Varistor : TVR-V Series



Disc Type Varistor for Surge Protection (Medium Surge Series)

■ Reliability

Item	Standard	Test conditions / Methods	Specifications															
Tensile Strength of Terminals	IEC 60068-2-21	Gradually apply the specified force and keep the unit fixed for 10±1 sec. Terminal diameter (mm) Force (Kg) 0.5<d≤0.8 1.0 0.8<d≤1.25 2.0	$ \Delta V_{1mA}/V_{1mA} \leq 5\%$ No visible damage															
Bending Strength of Terminals	IEC 60068-2-21	Hold specimen and apply the force specified below to each lead. Bend the specimen to 90°, then return to the original position. Repeat the procedure in the opposite direction. Terminal diameter (mm) Force (Kg) 0.5<d≤0.8 0.5 0.8<d≤1.25 1.0	$ \Delta V_{1mA}/V_{1mA} \leq 5\%$ No visible damage															
Vibration	IEC 61051-1	Frequency range: 10 ~ 55 Hz Amplitude: 0.75mm or 98 m/s ² Direction: 3 mutually perpendicular directions, 2 hrs each.	$ \Delta V_{1mA}/V_{1mA} \leq 5\%$ No visible damage															
Solderability	IEC 60068-2-20	245 ± 3 °C, 3 ± 0.3 sec	At least 95% of terminal electrode is covered by new solder															
Resistance to Soldering Heat	IEC 60068-2-20	260 ± 3 °C, 10 ± 1 sec	$ \Delta V_{1mA}/V_{1mA} \leq 5\%$ No visible damage															
High Temperature Storage	IEC 60068-2-2	125±5°C x 1000± 24 hrs	$ \Delta V_{1mA}/V_{1mA} \leq 5\%$ No visible damage															
Damp Heat, Steady State	IEC 60068-2-78	a. 40±2°C, 90 ~ 95 % RH, 1344 hrs b. 40±2°C, 90 ~ 95 % RH, at 10%Vdc, 1344 hrs	$ \Delta V_{1mA}/V_{1mA} \leq 5\%$ No visible damage Insulation Resistance ≥ 100MΩ															
Rapid Change of Temperature	IEC 60068-2-14	The conditions shown below shall be repeated 5 cycles <table border="1"> <thead> <tr> <th>Step</th> <th>Temperature (°C)</th> <th>Period (minutes)</th> </tr> </thead> <tbody> <tr> <td>1</td> <td>-40±3</td> <td>30±3</td> </tr> <tr> <td>2</td> <td>Room temperature</td> <td>5±3</td> </tr> <tr> <td>3</td> <td>85±2</td> <td>30±3</td> </tr> <tr> <td>4</td> <td>Room temperature</td> <td>5±3</td> </tr> </tbody> </table>	Step	Temperature (°C)	Period (minutes)	1	-40±3	30±3	2	Room temperature	5±3	3	85±2	30±3	4	Room temperature	5±3	$ \Delta V_{1mA}/V_{1mA} \leq 5\%$ No visible damage
Step	Temperature (°C)	Period (minutes)																
1	-40±3	30±3																
2	Room temperature	5±3																
3	85±2	30±3																
4	Room temperature	5±3																
Endurance at Upper Category Temperature	IEC 61051-1	85±2°C, 1000±24 hrs at V _{DC} or V _{rms} (Max. Continuous Voltage)	$ \Delta V_{1mA}/V_{1mA} \leq 10\%$ No visible damage															
8/20µs Surge Life	IEC 61051-1	8/20µs waveform, 10 surge currents, unipolar, interval 30 sec, amplitude corresponding to max. surge current derating curves for 20µs.	$ \Delta V_{1mA}/V_{1mA} \leq 10\%$ No visible damage															
10/1000µs Surge Life	IEC 61051-1	10/1000µs waveform, 10 surge currents, unipolar, interval 2 mins, amplitude corresponding to max. surge current derating curves for 1000µs.	$ \Delta V_{1mA}/V_{1mA} \leq 10\%$ No visible damage															
Operating Duty Cycle Test	UL 1449 3 rd	6KV/3KA 1.2/50µs +8/20µs combination waveform with Vac(@ Deg 90) for 15 times. Interval time between tests is 60 sec. (For TVR10-V series test only)	$ \Delta V_p/V_p \leq 10\%$ No visible damage															
Nominal Discharge Current Test	UL 1449 3 rd	3KA 8/20µs waveform with Vac (@ Deg 90) for 15 times. Interval time between tests is 60 sec. (For TVR14-V (SPD Type 5) series test only)	$ \Delta V_p/V_p \leq 10\%$ No visible damage															
Voltage Proof	IEC 61051-1	Metal balls method, 2500 Vac 1 min	No visible damage															
Varistor Voltage Temp. Coefficient	Specification Standard	$\frac{V_{1mA@85^\circ C} - V_{1mA@25^\circ C}}{V_{1mA@25^\circ C}} \times \frac{1}{60} \times 100\% (\% / ^\circ C)$, $\frac{V_{1mA@-40^\circ C} - V_{1mA@25^\circ C}}{V_{1mA@25^\circ C}} \times \frac{1}{65} \times 100\% (\% / ^\circ C)$	-0.05 ≤ TC ≤ 0.05 (%/°C)															

Metal Oxide Varistor : TVR-V Series



Disc Type Varistor for Surge Protection (Medium Surge Series)

■ Packaging

● Taping Specification

S Type (Straight lead)

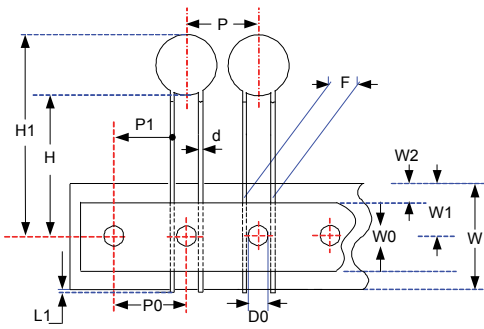

Figure A

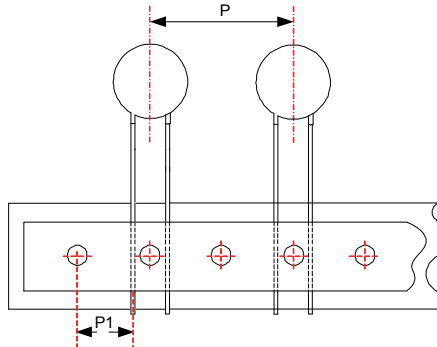

Figure B

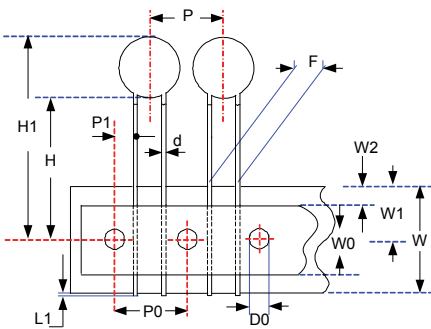
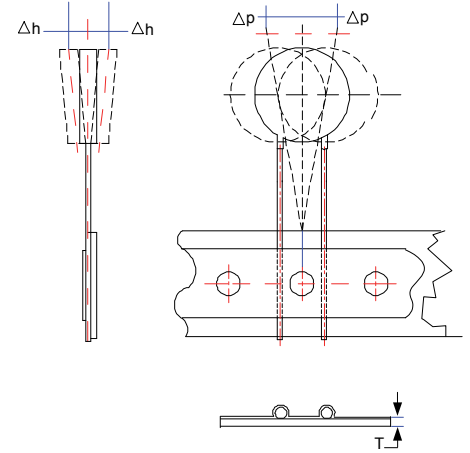

Figure C

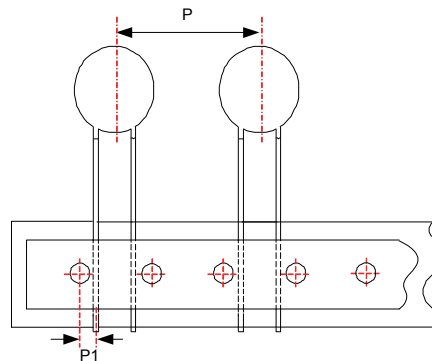

Figure D

(Unit: mm)

Taping Code	Series	P ₀	F	P	P ₁	H	H ₁	d	W ₀	W ₁	W ₂	W	ΔP	Δh	L ₁	D ₀	T	Figure
		±0.3	±1	±1	±0.7	+2/-0	Max.	±0.02	±1	+0.75/-0.5	Max	+1/-0.5	Max.	Max.	Max.	±0.2	±0.2	
A (P ₀ :12.7)	10-V	12.7	7.5	12.7	8.95	18	33.5	0.8	12	9	3	18	1	2	0.5	4	0.6	A
	14-V	12.7	7.5	25.4	8.95	18	38.0	0.8	12	9	3	18	1	2	0.5	4	0.6	B
E (P ₀ :15.0)	10-V	15	7.5	15.0	3.75	18	33.5	0.8	12	9	3	18	1	2	0.5	4	0.6	C
	14-V	15	7.5	30.0	3.75	18	38.0	0.8	12	9	3	18	1	2	0.5	4	0.6	D

Metal Oxide Varistor : TVR-V Series



Disc Type Varistor for Surge Protection (Medium Surge Series)

F Type (Y kink lead)

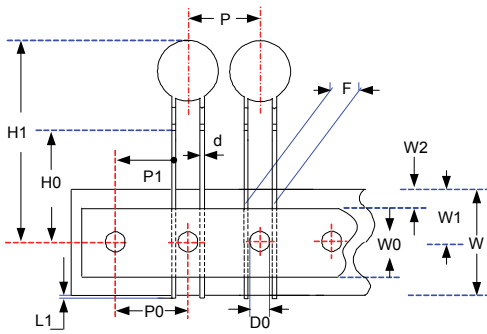

Figure A

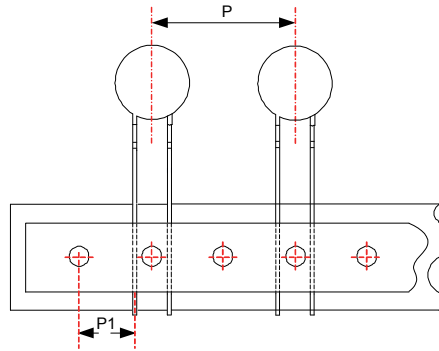

Figure B

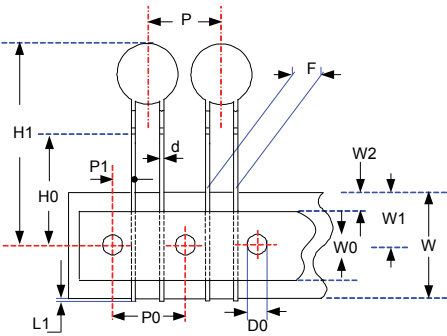
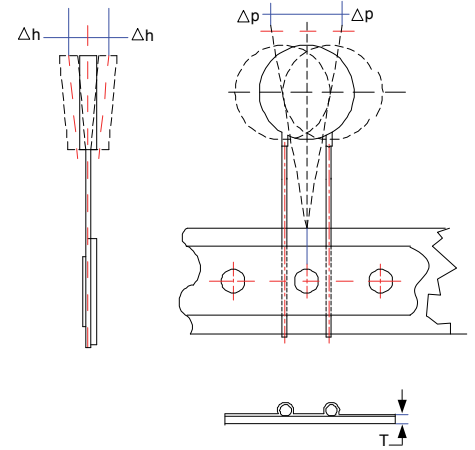

Figure C

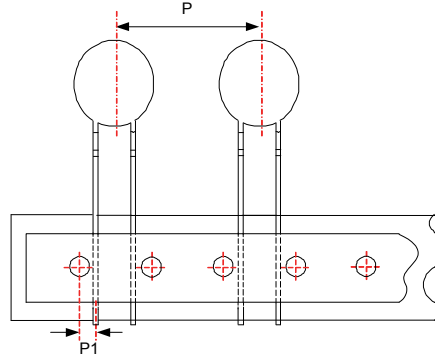

Figure D

(Unit: mm)

Taping Code	Series	P ₀	F	P	P ₁	H ₀	H ₁	d	W ₀	W ₁	W ₂	W	ΔP	Δh	L ₁	D ₀	T	Figure
		±0.3	±1	±1	±0.7	±0.5	Max.	±0.02	±1	+0.75/ -0.5	Max	+1/ -0.5	Max.	Max.	Max.	±0.2	±0.2	
A (P ₀ :12.7)	10-V	12.7	7.5	12.7	8.95	16	33.5	0.8	12	9	3	18	1	2	0.5	4	0.6	A
	14-V	12.7	7.5	25.4	8.95	16	38.0	0.8	12	9	3	18	1	2	0.5	4	0.6	B
E (P ₀ :15.0)	10-V	15.0	7.5	15.0	3.75	16	33.5	0.8	12	9	3	18	1	2	0.5	4	0.6	C
	14-V	15.0	7.5	30.0	3.75	16	38.0	0.8	12	9	3	18	1	2	0.5	4	0.6	D

Metal Oxide Varistor : TVR-V Series



Disc Type Varistor for Surge Protection (Medium Surge Series)

Quantity

Bulk Packing

Series	Quantity (pcs/bag)
TVR10-V	200
TVR14-V	100

Reel Packing

Series	A (mm)	Quantity (pcs/reel)
TVR10(201~471)-V	46	750
TVR10(511~112)-V		500
TVR14(201~391)-V		750
TVR14(431~112)-V		500

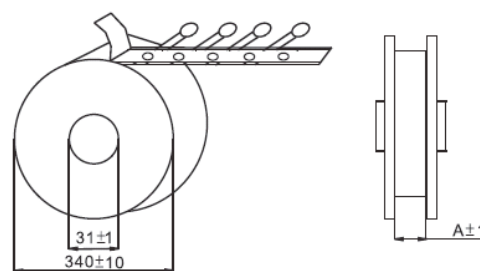

(Unit: mm)

Ammo Packing

Series	Quantity (pcs/box)
TVR10(201~361)-V	750
TVR10(391~621)-V	500
TVR10(681~112)-V	400
TVR14(201~271)-V	500
TVR14(301~112)-V	250

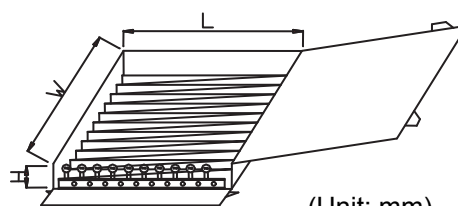

(Unit: mm)

Series	W±5	L±5	H±5
TVR10-V	348	275	60
TVR14-V	348	185	60

Warehouse Storage Conditions of Products

Storage Conditions:

1. Storage Temperature: $-10^{\circ}\text{C} \sim +40^{\circ}\text{C}$
2. Relative Humidity: $\leq 75\% \text{RH}$
3. Keep away from corrosive atmosphere and sunlight.

Period of Storage: 1 year