



DDR and SDRAM Buffer

Recommended Application:

DDR & SDRAM fanout buffer, for VIA P4X/KT266/333 chipsets.

Product Description/Features:

- Low skew, fanout buffer
- 1 to 12 differential clock distribution
- I²C for functional and output control
- Feedback pin for input to output synchronization
- Supports up to 4 DDR DIMMs or 3 SDRAM DIMMs + 2 DDR DIMMs
- Frequency supports up to 200MHz (DDR400)
- Supports Power Down Mode for power management
- CMOS level control signal input

Switching Characteristics:

- OUTPUT - OUTPUT skew: <100ps SDRAM
OUTPUT - OUTPUT skew: <150ps DDR
- Output Rise and Fall Time for DDR outputs: 600ps - 950ps
- DUTY CYCLE: 47% - 53% DDR
DUTY CYCLE: 45%- 55% SDRAM

Pin Configuration

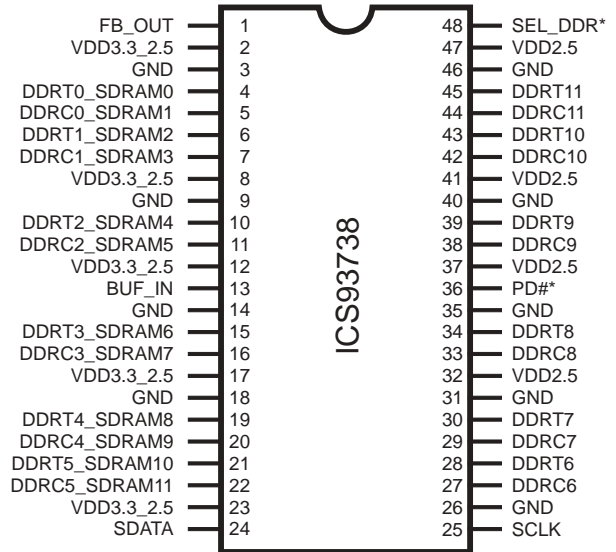

48-Pin SSOP

*Internal Pull-up Resistor of 120K to VDD

Block Diagram

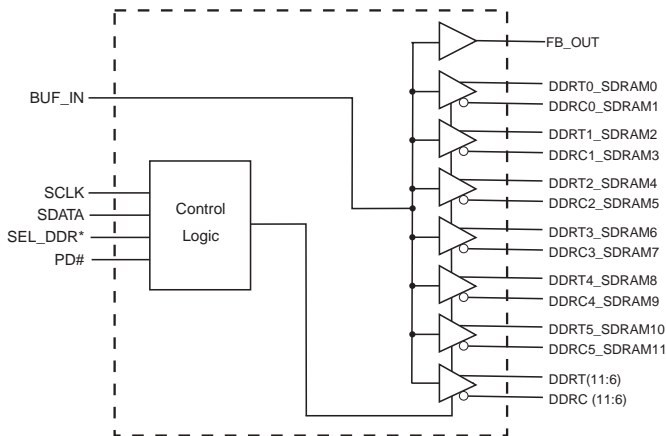

Functionality

MODE	PIN 48	VDD 3.3_2.5	PIN 4, 5, 6, 7, 10, 11, 15, 16, 19, 20, 21, 22
DDR Mode	SEL_DDR=1	2.5V	These outputs will be DDR outputs
DDR/SD Mode	SEL_DDR=0	3.3V	These outputs will be standard SDRAM outputs



Pin Descriptions

PIN NUMBER	PIN NAME	TYPE	DESCRIPTION
1	FB_OUT	OUT	Feedback output, dedicated for external feedback
2, 8, 12, 17, 23,	VDD3.3_2.5	PWR	2.5V or 3.3V voltage supply to pins 4, 5, 6, 7, 10, 11, 15, 16, 19, 20, 21, 22
3, 9, 14, 18, 26, 31, 35, 40, 46	GND	PWR	Ground
45, 43, 39, 34, 30, 28,	DDRT (11:6)	OUT	"True" Clock of differential pair outputs.
44, 42, 38, 33, 29, 27,	DDRC (11:6)	OUT	"Complementary" clocks of differential pair outputs.
21, 19, 15, 10, 6, 4	DDRT (5:0) SDRAM (10, 8, 6, 4, 2, 0)	OUT	"True" Clock of differential pair outputs, or 3.3V SDRAM clock outputs depending on SEL_DDR input
22, 20, 16, 11, 7, 5	DDRC (5:0) SDRAM (11, 9, 7, 5, 3, 1,)	OUT	"Complementary" clocks of differential pair outputs, or 3.3V SDRAM clock outputs depending on SEL_DDR input
13	BUF_IN	IN	Single ended buffer input
24	SDATA	I/O	Data pin for I ² C circuitry 5V tolerant
25	SCLK	IN	Clock input of I ² C input, 5V tolerant input
32, 37, 41, 47	VDD2.5	PWR	2.5V voltage supply
36	PD#	IN	Asynchronous active low input pin used to power down the device into a low power state. The internal clocks are disabled. The latency of the power down will not be greater than 3ms.
48	SEL_DDR	IN	Select input for DDR mode or DDR/SD mode 0=DDR/SD mode 1=DDR mode



Byte 6: Output Control
(1= enable, 0 = disable)

BIT	PIN#	PWD	DESCRIPTION
Bit 7	48	1	SEL_DDR (Read back only)
Bit 6	-	1	(Reserved)
Bit 5	-	1	(Reserved)
Bit 4	-	1	(Reserved)
Bit 3	45, 44	1	DDRT11, DDRC11
Bit 2	43, 42	1	DDRT10, DDRC10
Bit 1	39, 38	1	DDRT9, DDRC9
Bit 0	34, 33	1	DDRT8, DDRC8

Byte 7: Output Control
(1= enable, 0 = disable)

BIT	PIN#	PWD	DESCRIPTION
Bit 7	30, 29	1	DDRT7, DDRC7
Bit 6	28, 27	1	DDRT6, DDRC6
Bit 5	21, 22	1	DDRT5, SDRAM10 DDRC5_SDRAM11
Bit 4	19, 20	1	DDRT4_SDRAM8 DDRC4_SDRAM9
Bit 3	15, 16	1	DDRT3_SDRAM6 DDRC3_SDRAM7
Bit 2	10, 11	1	DDRT2_SDRAM4 DDRC2_SDRAM5
Bit 1	6, 7	1	DDRT1_SDRAM2 DDRC1_SDRAM3
Bit 0	4, 5	1	DDRT0_SDRAM1 DDRC0_SDRAM0



Absolute Maximum Ratings

Supply Voltage (VDD & VDD2.5)	-0.5V to 3.6V
Logic Inputs	GND -0.5 V to V _{DD} +0.5 V
Ambient Operating Temperature	0°C to +85°C
Case Temperature	115°C
Storage Temperature	-65°C to +150°C

Stresses above those listed under *Absolute Maximum Ratings* may cause permanent damage to the device. These ratings are stress specifications only and functional operation of the device at these or any other conditions above those listed in the operational sections of the specifications is not implied. Exposure to absolute maximum rating conditions for extended periods may affect product reliability.

Electrical Characteristics - Input / Supply / Common Output Parameters - SDRAM

SEL_DDR=0, SDRAM Outputs, V_{DD3.3_2.5} = 3.3V, T_A = 0 - 85°C (unless otherwise stated)

PARAMETER	SYMBOL	CONDITIONS	MIN	TYP	MAX	UNITS
Input High Current	I _{IH}	V _{IN} = V _{DD} or GND			10	μA
Input Low Current	I _{IL}	V _{IN} = V _{DD} or GND	-100			μA
Operating Supply Current	I _{DD3.3_2.5}	C _L = 0 pF at 133 MHz		170	250	mA
	I _{DD2.5}	C _L = 0 pF at 133 MHz		90	200	mA
	I _{DDPD}	C _L = 0 pF		0	10	μA
Output High Current	I _{OH}	V _{DD} = 3.3V, V _{OUT} = 1V			-18	mA
Output Low Current	I _{OL}	V _{DD} = 3.3V, V _{OUT} = 1.2V	26			mA
High-level Output Voltage	V _{OH}	V _{DD} = 3.3V, I _{OH} = -12mA	2			V
Low-level Output Voltage	V _{OL}	V _{DD} = 3.3V, I _{OL} = 12mA			0.4	V
Input Capacitance ¹	C _{IN}	V _{IN} = V _{DD} or GND				pF

1. Guaranteed by design, not 100% tested in production.

Recommended Operating Conditions - SDRAM

SEL_DDR=0, SDRAM Outputs, V_{DD3.3_2.5} = 3.3V, T_A = 0 - 85°C (unless otherwise stated)

PARAMETER	SYMBOL	CONDITIONS	MIN	TYP	MAX	UNITS
Power Supply Voltage	V _{DD3.3_2.5}		3	3.3	3.6	V
	V _{DD2.5}		2.5	2.5	2.7	
Input High Voltage	V _{IH}	SEL_DDR, PD# inputs	2			V
Input Low Voltage	V _{IL}	SEL_DDR, PD# inputs			0.8	V
Input Voltage Level	V _{IN}					V



Electrical Characteristics - Input / Supply / Common Output Parameters - DDR

SEL_DDR=1, DDR/DDR_SDRAM Outputs, $V_{DD3.3, 2.5} = 2.5V$, $T_A = 0 - 85^{\circ}C$ (unless otherwise stated)

PARAMETER	SYMBOL	CONDITIONS	MIN	TYP	MAX	UNITS
Input High Current	I_{IH}	$V_{IN} = V_{DD}$ or GND			10	μA
Input Low Current	I_{IL}	$V_{IN} = V_{DD}$ or GND	-100			μA
Operating Supply Current	$I_{DD3.3, 2.5}$	$C_L = 0$ pF at 133 MHz		125	200	mA
	$I_{DD2.5}$	$C_L = 0$ pF at 133 MHz		90	200	mA
	I_{DDPD}	$C_L = 0$ pF		0	10	μA
Output High Current	I_{OH}	$V_{DD} = 2.5V$, $V_{OUT} = 1V$			-18	mA
Output High Current	I_{OL}	$V_{DD} = 2.5V$, $V_{OUT} = 1.2V$	26			mA
High-level Output Voltage	V_{OH}	$V_{DD} = 2.5V$, $I_{OH} = -12mA$	1.7			V
Low-level Output Voltage	V_{OL}	$V_{DD} = 2.5V$, $I_{OL} = 12mA$			0.46	V
Output differential-pair crossing voltage ¹	C_{IN}		$V_{DD}/2$ 0.1	1.2	$V_{DD}/2 +$ 0.1	V
Input Capacitance ¹	C_{IN}	$V_{IN} = V_{DD}$ or GND				pF

1. Guaranteed by design, not 100% tested in production.

Recommended Operating Conditions - DDR

SEL_DDR=1, DDR/DDR_SDRAM Outputs, $V_{DD3.3, 2.5} = 2.5V$, $T_A = 0 - 85^{\circ}C$ (unless otherwise stated)

PARAMETER	SYMBOL	CONDITIONS	MIN	TYP	MAX	UNITS
Power Supply Voltage	$V_{DD3.3, 2.5}$		2.3	2.5	2.7	V
	$V_{DD2.5}$		2.5	2.5	2.7	
Input High Voltage	V_{IH}	SEL_DDR, PD# inputs	2			V
Input Low Voltage	V_{IL}	SEL_DDR, PD# inputs			0.8	V
Input Voltage Level	V_{IN}					V



Switching Characteristics

$T_A = 0 - 85^\circ\text{C}$

PARAMETER	SYMBOL	CONDITIONS	MIN	TYP	MAX	UNITS
Operating Frequency			66	133	200	MHz
Input clock duty cycle	d_{tin}		40	50	60	%
Output to output Skew ¹ (DDR outputs)	T_{skewDDR}	$V_T = 50\%$, Not including FB_OUT to outputs		80	150	ps
Output to output Skew ¹ (SDRAM outputs)	T_{skewSD}	$V_T = 1.5\text{V}$		70	100	ps
Duty Cycle ^{1,3} (DDR outputs)	DC_{DDR}	$V_T = 50\%$, 66 MHz to 100 MHz, w/loads	48	49	52	%
		$V_T = 50\%$, 101 MHz to 167 MHz, w/loads	47	50	53	
Duty Cycle ^{1,3} (SDRAM outputs)	DC_{SD}	$V_T = 1.5\text{V}$, w/loads	45	50	55	%
Rise Time, Fall Time ¹ (DDR outputs)	$t_{\text{rd}}, t_{\text{fd}}$	Single-ended 20 - 80 % 133 MHz, Load = $120\Omega / 12\text{ pF}$	600	800	950	ps
Rise Time, Fall Time ¹ (SDRAM outputs)	$t_{\text{rs}}, t_{\text{fs}}$	Single-ended $V_{\text{OL}} = 0.4\text{V}$, $V_{\text{OH}} = 2.4\text{V}$ 133 MHz, Load = 12 pF	0.5	1.5	1.7	ns
SDRAM Buffer LH Propagation Delay ^{1,2}	t_{PLH}	Input edge greater than 1V/ns		2	2.5	ns
SDRAM Buffer HL Propagation Delay ^{1,2}	t_{PHL}	Input edge greater than 1V/ns		1.9	2.5	ns

1. Guaranteed by design, not 100% tested in production.
2. Refers to transition on non-inverting output.
3. While the pulse skew is almost constant over frequency, the duty cycle error increases at higher frequencies.
This is due to the formula: duty cycle = t_2 / t_1 , where the cycle time (t_1) decreases as the frequency increases.

Switching Waveforms

Duty Cycle Timing

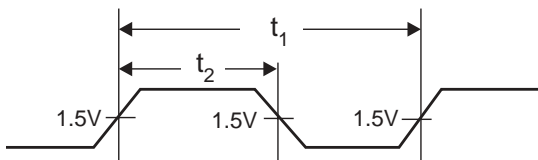

SDRAM Buffer LH and HL Propagation Delay

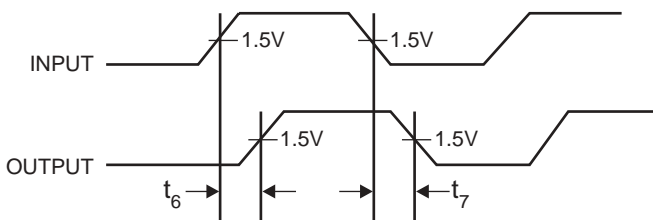



General I²C serial interface information

The information in this section assumes familiarity with I²C programming.
For more information, contact ICS for an I²C programming application note.

How to Write:

- Controller (host) sends a start bit.
- Controller (host) sends the write address D4_(H)
- ICS clock will **acknowledge**
- Controller (host) sends a dummy command code
- ICS clock will **acknowledge**
- Controller (host) sends a dummy byte count
- ICS clock will **acknowledge**
- Controller (host) starts sending first byte (Byte 0) through byte 6
- ICS clock will **acknowledge** each byte *one at a time*.
- Controller (host) sends a Stop bit

How to Write:	
Controller (Host)	ICS (Slave/Receiver)
Start Bit	
Address D4 _(H)	
	ACK
Dummy Command Code	
	ACK
Dummy Byte Count	
	ACK
Byte 0	
	ACK
Byte 1	
	ACK
Byte 2	
	ACK
Byte 3	
	ACK
Byte 4	
	ACK
Byte 5	
	ACK
Byte 6	
	ACK
Byte 7	
	ACK
Stop Bit	

How to Read:

- Controller (host) will send start bit.
- Controller (host) sends the read address D5_(H)
- ICS clock will **acknowledge**
- ICS clock will send the **byte count**
- Controller (host) acknowledges
- ICS clock sends first byte (**Byte 0**) through **byte 7**
- Controller (host) will need to acknowledge each byte
- Controller (host) will send a stop bit

How to Read:	
Controller (Host)	ICS (Slave/Receiver)
Start Bit	
Address D5 _(H)	
	ACK
	Byte Count
ACK	
	Byte 0
ACK	
	Byte 1
ACK	
	Byte 2
ACK	
	Byte 3
ACK	
	Byte 4
ACK	
	Byte 5
ACK	
	Byte 6
ACK	
	Byte 7
Stop Bit	

Notes:

1. The ICS clock generator is a slave/receiver, I²C component. It can read back the data stored in the latches for verification. **Read-Back will support Intel PIIX4 "Block-Read" protocol.**
2. The data transfer rate supported by this clock generator is 100K bits/sec or less (standard mode)
3. The input is operating at 3.3V logic levels.
4. The data byte format is 8 bit bytes.
5. To simplify the clock generator I²C interface, the protocol is set to use only "**Block-Writes**" from the controller. The bytes must be accessed in sequential order from lowest to highest byte with the ability to stop after any complete byte has been transferred. The Command code and Byte count shown above must be sent, but the data is ignored for those two bytes. The data is loaded until a Stop sequence is issued.
6. At power-on, all registers are set to a default condition, as shown.

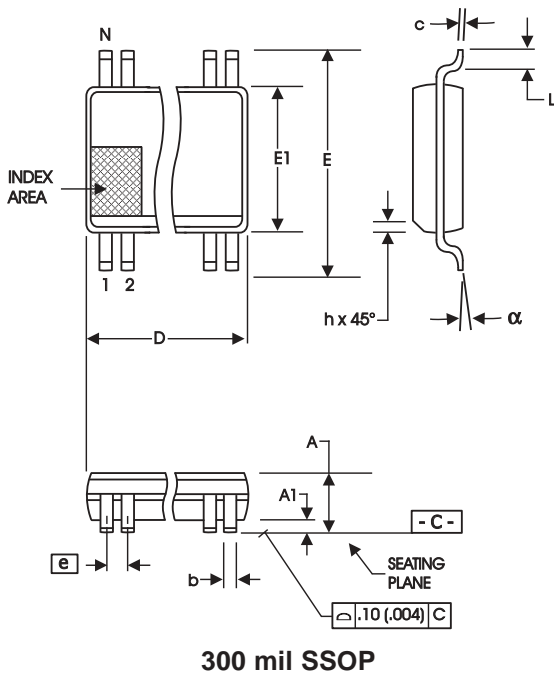

300 mil SSOP

SYMBOL	In Millimeters COMMON DIMENSIONS		In Inches COMMON DIMENSIONS	
	MIN	MAX	MIN	MAX
A	2.41	2.80	.095	.110
A1	0.20	0.40	.008	.016
b	0.20	0.34	.008	.0135
c	0.13	0.25	.005	.010
D	SEE VARIATIONS		SEE VARIATIONS	
E	10.03	10.68	.395	.420
E1	7.40	7.60	.291	.299
e	0.635 BASIC		0.025 BASIC	
h	0.38	0.64	.015	.025
L	0.50	1.02	.020	.040
N	SEE VARIATIONS		SEE VARIATIONS	
α	0°	8°	0°	8°

VARIATIONS

N	D mm.		D (inch)	
	MIN	MAX	MIN	MAX
48	15.75	16.00	.620	.630

Reference Doc.: JEDEC Publication 95, MO-118

10-0034

Ordering Information

ICS93738yFT

Example:

ICS XXXX y F - T

