

AS8118**Single Phase Instantaneous Energy Metering IC
with On-Chip Calibration, Stepper Motor Drive and LED Output****FEATURES****Features**

- Extremely accurate, surpassing the accuracy requirements of the IEC 1036 Specification less than 0.1% error over a 600 : 1 dynamic range
- On-chip programmable current input gain suitable for use with low-resistance shunt resistor or current transformer
- On-chip programming for output pulse rate selection
- On-chip calibration eliminates the need for an external resistor network or trim-potentiometer
- Programmable on-chip creep prevention under no-load condition
- All on-chip programmable functions may be reprogrammed a second time
- Outputs directly drive an electromechanical counter or counters with a two phase stepper motor and consumption LED indicator
- Fast calibration pulse output for high speed manual or automated calibration
- On-chip voltage reference and power supply monitoring
- Bi-directional or unidirectional energy measurement, with direction indication output available

Description

The AS8118 is a very accurate single-phase bi-directional *instantaneous* energy measurement integrated circuit, which surpasses all the accuracy requirements for IEC1036 alternating current static watt-hour meters. The measured energy is converted into pulses with the number of output pulses being proportional to the measured energy.

The AS8118 is ideal for use in 'stand alone' kWh meter applications, where the IC directly drives an electromechanical counter with a two-phase stepper motor, or for more complex meter applications, the AS8118 interfaces directly to a micro-controller.

The highly integrated AS8118 design includes all the required functional blocks. The blocks comprise of analog to digital converters (ADC) for the voltage and current channels, digital filters, a digital signal processing block, a

control block and non-volatile calibration memory for the on-chip programming. The on-chip programming enables the setting of the current input gain, the anti-creep threshold, the output pulse rates and the system calibration. The high level of integration ensures a minimum number of non-critical external components are required.

The on-chip anti-creep circuit ensures that the AS8118 does not output pulses when the meter is in a no-load condition and that the IEC1036 anti-creep test requirements are fully complied with, for both direct or transformer connection meters.

The AS8118 offers three different pulse outputs. A stepper motor drive output for directly driving a stepper motor display, a LED output for energy consumption indication and a dedicated high frequency output for fast single point system calibration.

The AS8118 is available in either surface mount SOIC-18 or dual-in-line DIP-18 packages.

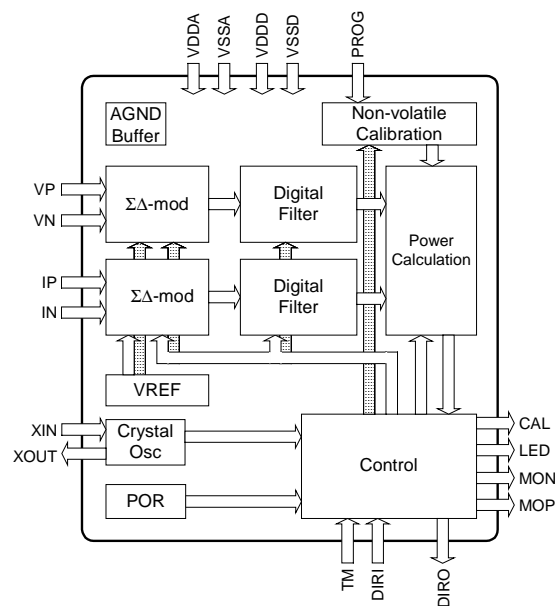
Block Diagram

Figure 1 Block diagram of the AS8118